

## Telephone Line

### RTU Modules



The Telephone RTU system consists of a pair of devices, a transmitter and a receiver that allow the transmission of 4 analog and 4 digital signals over a twisted pair or dedicated telephone line. The signals are encoded and transmitted as a unidirectional FSK signal. The 4 analog input signals at the transmitter are multiplexed to a single analog output at the receiver. There are 2 selection inputs on the receiver to determine which signal appears at the output.

The four digital inputs at the transmitter are presented as four digital outputs on the receiver. There is a fifth digital output which is activated when the communications link is broken.

Both the receiver and the transmitter are housed in a metal enclosure with a TS35 rail mounting foot. Optional brackets may be installed for panel mounting. Contact the factory for details.

The Telephone RTU works on any twisted pair (with distance limitations) or any telephone line that is unpowered and has no dial tone. In Ontario the units were tested on a 9600bps analog line, "Sched 4 Type 4" provided by Bell. This type of line allows almost any transmission distance to be covered since the maximum input to output loss is guaranteed.

The transmission speed is 600bits per second of FSK encoded data. Each transmission "package" consists of 16 bytes (of 12 bits length). The protocol itself has been written specifically for this application.

The units have been designed to meet North American telephone interface standards and are isolated from the telephone line by 600 ohm transformers.

Connection is achieved through the 6 way RJ11 (telephone) connectors. Irrespective of whether communications is to occur over the telephone line as described above, or a twisted pair only the two middle pins (pins 3 and 4) are used. Pin 2 of the transmitter is connected to pin 2 of the receiver. Pin 3 of the transmitter is connected to pin 3 of the receiver. See figure 1.

#### United States

Weidmuller Inc.  
821 Southlake Blvd.  
Richmond, Virginia 23236  
Telephone: (800) 849-9343  
Facsimile: (804) 379-2593  
Email: info@weidmuller.com  
Website: www.weidmuller.com

#### Canada

Weidmuller Ltd.  
10 Spy Court  
Markham, Ontario L3R 5H6  
Telephone: (800) 268-4080  
Facsimile: (905) 475-2798  
Email: info1@weidmuller.ca  
Website: www.weidmuller.ca

#### Mexico

Weidmuller, S.A. de C.V.  
5 Sur No. 4311  
Col. Huexotitla  
72534 Puebla, Pue. Mexico  
Telephone: (22) 37 2549  
Facsimile: (22) 43 1981  
Email: weidmull@acnet.net

# Telephone Line RTU

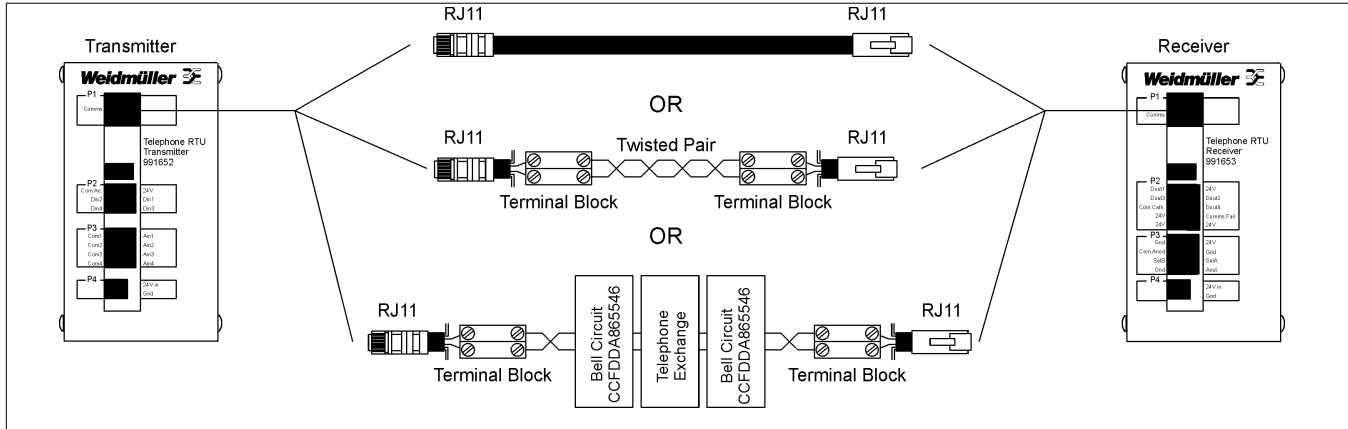
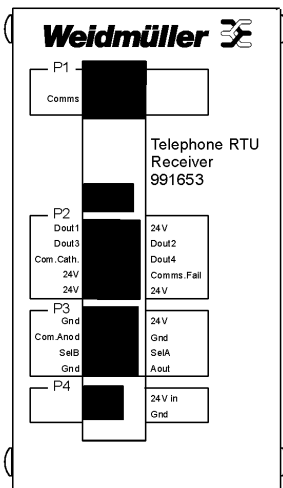
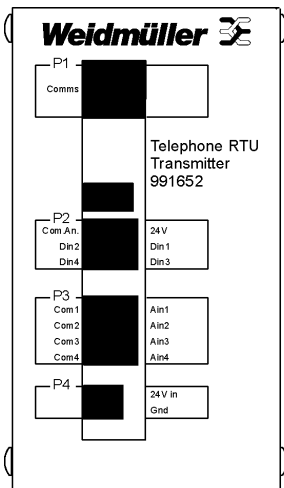

Figure 1 - Interconnection

### Specifications:

Typical transmission medium	twisted pair or analog telephone data line, no dial tone, unpowered (in Ontario this is 9600 bps, "Sched 4 Type 4")
Transmission Speed	600 bps, 16 bytes, 12 bits per byte
Transmission Protocol:	Proprietary
Transmission Interface	600Ω transformer coupled
Communications Failure	Delay of 3 seconds.
<b>Analog:</b>	
Accuracy at 25°C:	0.08% ± 1 bit typical (based on 0.1% input resistors)
Step Function Response	600-1700ms (typical)
Minimum pulse width (high or low)	300ms (typical)
Maximum Frequency (sine wave)	0.1Hz (typical)
<b>Digital:</b>	
Step Function Response	600-1550ms (typical)
Minimum digital input pulse width (high or low)	450ms (typical)
Maximum Frequency	0.1Hz (typical)



# Telephone Line RTU

## Specifications:

### Power Supply Voltage

### Supply Current (typical)

### Analog Input

Analog Input Impedance 0-10Vdc input

(nominal-using recommended values): 0-20mA input

### Accuracy

### Digital Input Current

### LED Flash rate

### Operational Temp

### Catalog Number

Transmitter Module

## Transmitter Module

15-30Vdc

120mA @ 15V, 80mA @24V, 75mA @ 30V

4 inputs, resistor selectable 0-20mA (factory setting) or 0-10Vdc

other ranges possible, contact Weidmuller

20kΩ (use 2 x 10kΩ, 0.1% per channel)

250Ω (use 1 x 250Ω, 0.1% per channel)

±0.1% across temperature range

6mA @ 30Vdc supply

5mA @ 24Vdc supply

3mA @ 15Vdc supply

As a result of the low current gold plated contacts should be used, or electronic drivers.

$I_{in} = (V - 1.6) / 4700$  where V is the voltage supplied to the anode of the input opto

(marked Com.An.).

250ms on, 250ms off

-20° to 70°C

991652 0000

Use the following table to determine which resistors to change for a given input configuration. Recommended values are  $R_x = R_y = 4.99k\Omega$ , 0.1% for 0-10Vdc input or  $R_y = 10\Omega$ ,  $R_y = 250\Omega$  ohms, 0.1% for 20mA input. Default is 0-20mA.

	Ain1	Ain2	Ain3	Ain4
R <sub>x</sub>	R15	R6	R17	R18
R <sub>y</sub>	R2	R4	R6	R8

Calibration: see Application Notes

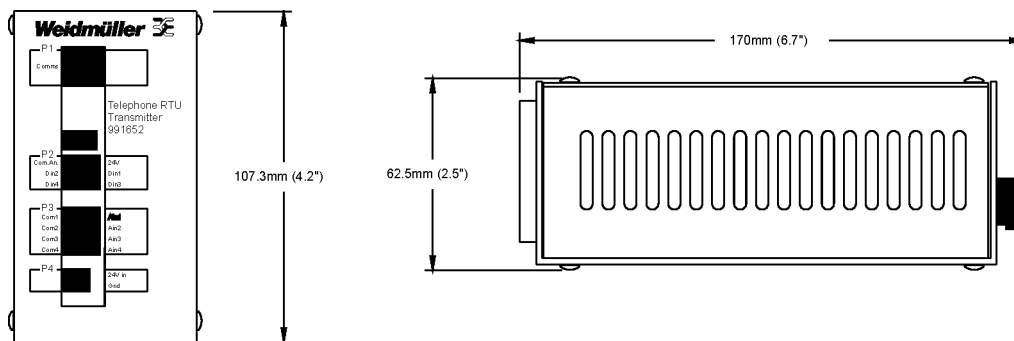

Figure 2 - Dimensions

Contact Weidmuller for the “Telephone RTU” Application Guide or download it from our website [www.weidmuller.ca](http://www.weidmuller.ca)

# Telephone Line RTU

Specifications:		Receiver Module
Power Supply Voltage		15-30Vdc
Supply Current (typical)		135mA @ 15V, 120mA @24V, 125mA @ 30V
Analog Output:		Jumper configurable 0-20mA (factory setting) or 0-10Vdc (other ranges possible, contact Weidmuller). Single output
<b>Accuracy</b>		±0.1% across temperature range
<b>Analog Drive Output:</b>		
<b>Voltage output</b>	<b>10mA @ 10V</b>	1000Ω min.
<b>Current output</b>	<b>20mA output</b>	≤500Ω over full supply voltage range
<b>R<sub>L</sub> max (20mA out)</b>		((50*Vs)-200 where R <sub>L</sub> is the load in ohms and Vs is the supply voltage.
<b>Digital Input</b>		Analog Channel Selection: SelA, B
<b>Digital Input</b>		2, Optically Isolated
<b>Digital Input Current</b>		6mA @ 30Vdc supply 5mA @ 24Vdc supply 3mA @ 15Vdc supply.
		As a result of the low current gold plated contacts should be used, or electronic drivers. $I_{in}=(V-1.6)/4700$ where V is the voltage supplied to the anode of the input LED (marked Com.An.).
<b>Digital Output</b>		Built-in Back EMF diodes for direct relay drive.
<b>Standoff Voltage</b>		50Vdc
<b>Maximum Output Current</b>		100mA
<b>Maximum On voltage @ 100mA</b>		1Vdc (typical)
<b>Digital Output</b>		5, Open collector (4 associated with the inputs, 1 for communications failure). Built-in back EMF diodes for all outputs- commoned at Com.Kt When an input is active, (current flowing through the LED input) the associated output will be active (sinking current). When there has been a communications failure, the COMMUNICATION FAILURE output will go active (sinking current).
<b>LED Flash rate(nominal):</b>		
	<b>Communications Active</b>	300ms on, 300ms off
	Communications Inactive	1.5s on 1.5s off
Operational Temp	Transmitter	-10° - 70°C
<b>Catalog Numbers</b>		
Receiver Module		991653 0000

There is a single analog output. It may be configured for voltage or current output by setting a jumper. Ranges may be adjusted away from 0-20mA (factory setting) and 0-10V, see Application Note "Telephone RTU" for details.

<b>J3</b>	<b>1 - 2</b>	<b>mA out</b>
<b>J3</b>	<b>2 - 3</b>	<b>Vout</b>

For convenience, Channel 1 is presented when the channel selection is disconnected.

	SelA	SelB
Aout1		
Aout2	Active	
Aout3		Active
Aout4	Active	Active

Calibration: see Application Notes