

Overview HDC

Aid for selection	Construction of heavy-duty connectors – fixed pole	A.2	
	Overview of size 1 – fixed pole	A.3	
	Overview of sizes 2, 5, 7, 9 – fixed pole	A.4	
	Overview of sizes 3, 4, 6, 8, 10, 12 – fixed pole	A.5	
	Overview of size HQ – fixed-pole	A.6	
	Construction of heavy-duty connectors – modular	A.8	
	Overview of sizes 3, 4, 6, 8, 10, 12 – modular	A.9	
	Panel cut-out	A.10	
	Classes of protection	A.12	
	RockStar® Housing types	A.14	
	Fastening systems	A.16	
	Part codes for inserts and covers	A.18	
	Part codes for housings	A.19	
	Technical data	Connection systems	A.20
		Electrical data	A.22
		Chemical resistance	A.26
		Tightening torques and screwing tools	A.27
		Clamping range and ferrules	A.28
		Safety information / standards	A.29

Construction of heavy-duty connectors – fixed pole

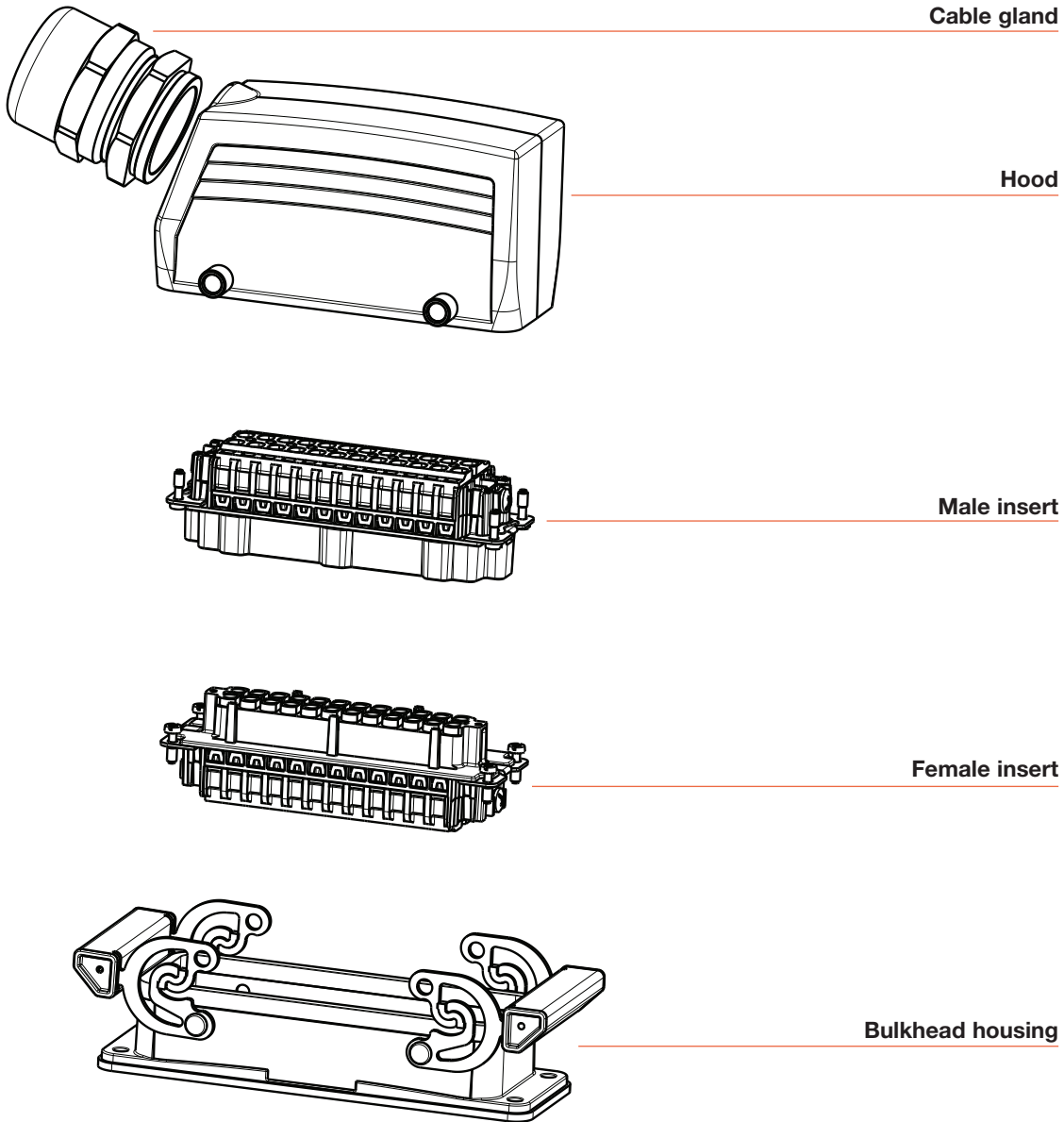

Overview of size 1 – fixed pole

Size

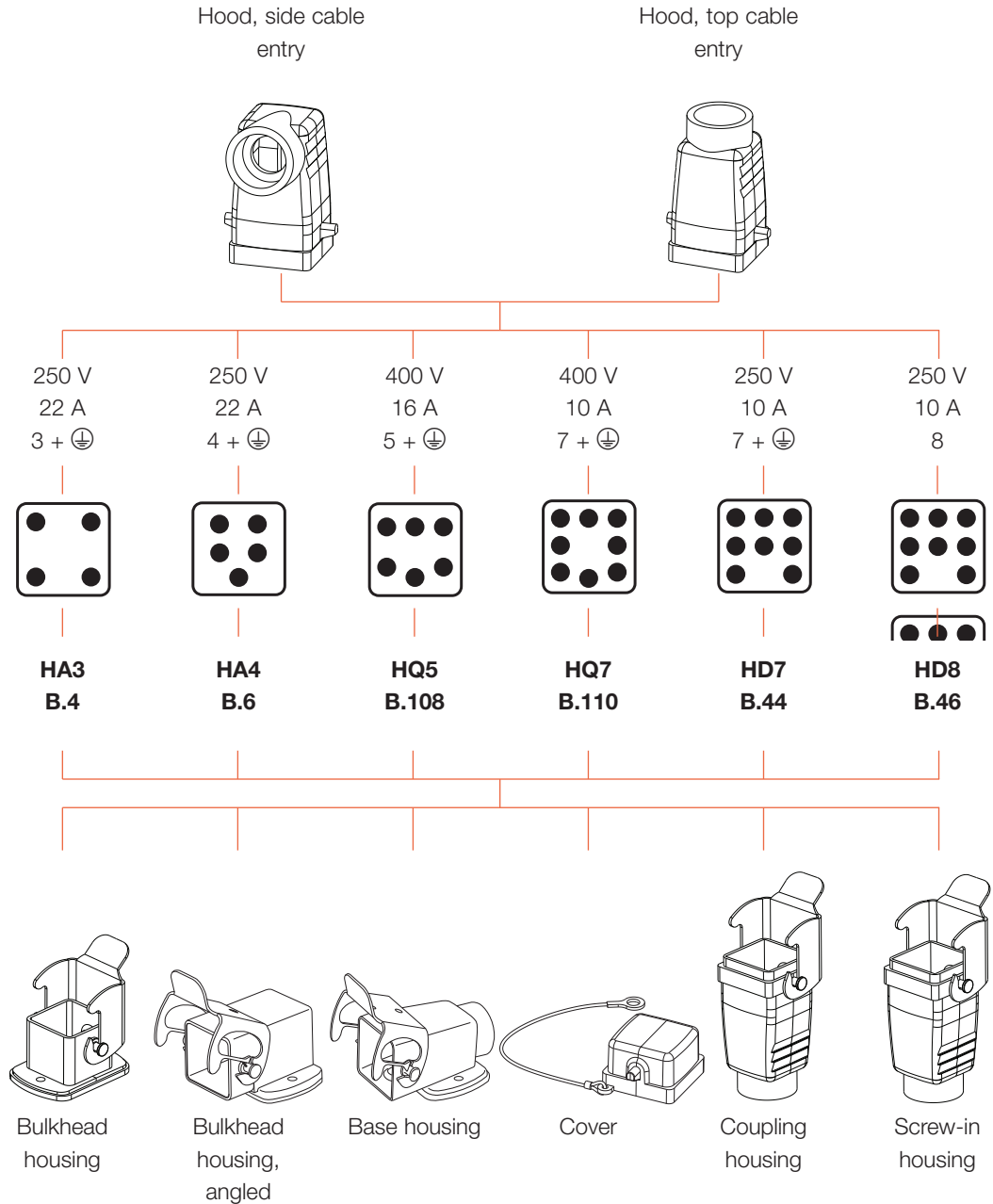

Overview of sizes 2, 5, 7, 9 – fixed pole

A

Size

Hood, side cable entry

Hood, top cable entry

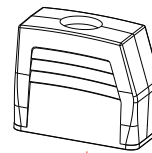
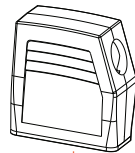

2

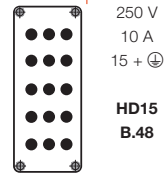
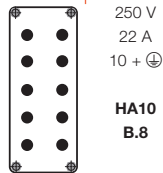

5

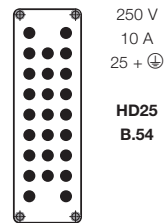
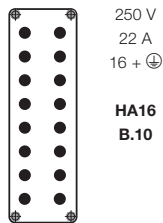

7

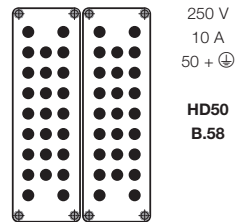
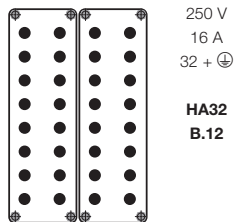

9

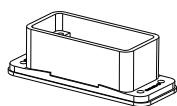
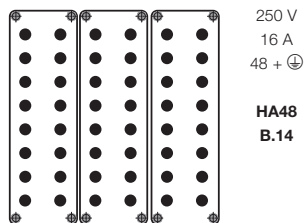

Bulkhead housing

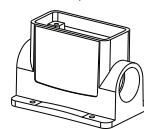

Base housing

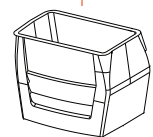

Coupling housing

Overview of sizes 3, 4, 6, 8, 10, 12 – fixed pole

Size

Hood, side cable entry

Hood, top cable entry

3

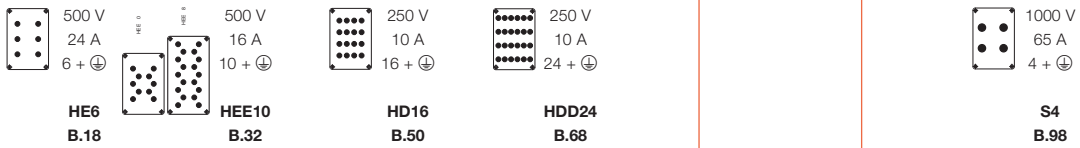

4

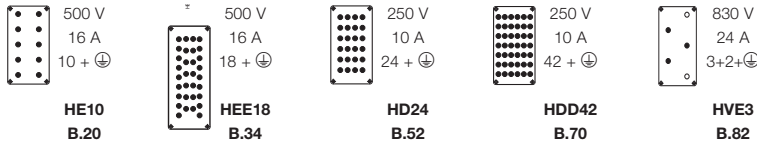

6

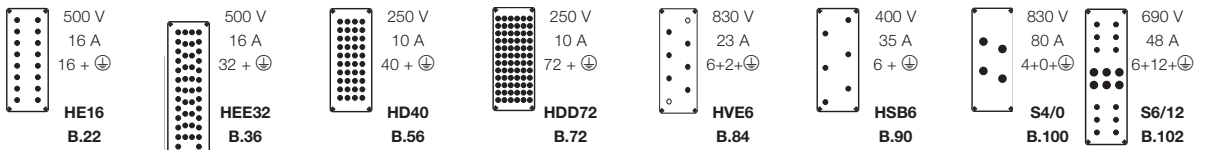

8

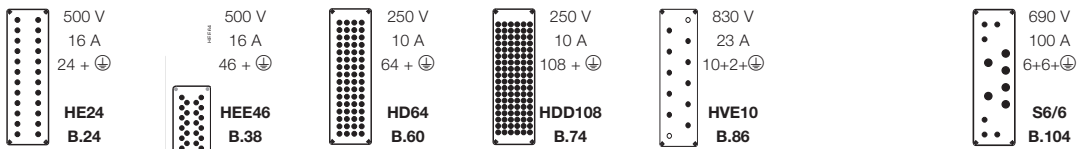

10

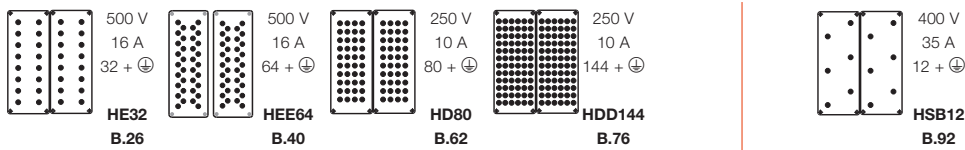

12

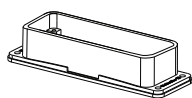
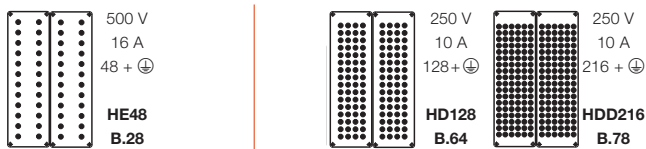

Bulkhead housing

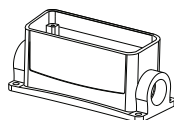

Base housing

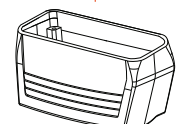

Coupling housing

Overview of size HQ – fixed-pole

A

Size

TSLU

TOLU

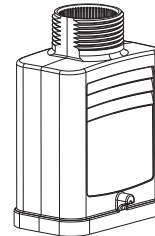
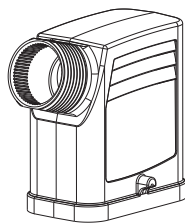

500 V
16 A
8 + ⊕

250 V
10 A
17 + ⊕

630 V
40 A
4+2 + ⊕



HQ8
B.112

HQ17
B.114

HQ42
B.116

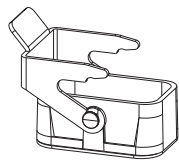

Bulkhead housing

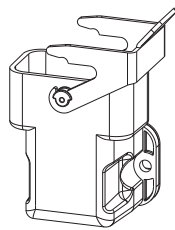

Bulkhead housing,
angled

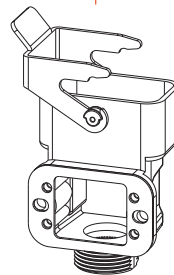

Base housing

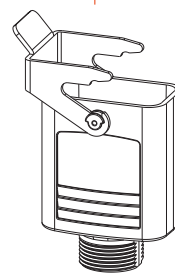

Coupling housing



Cover

Construction of heavy-duty connectors – modular

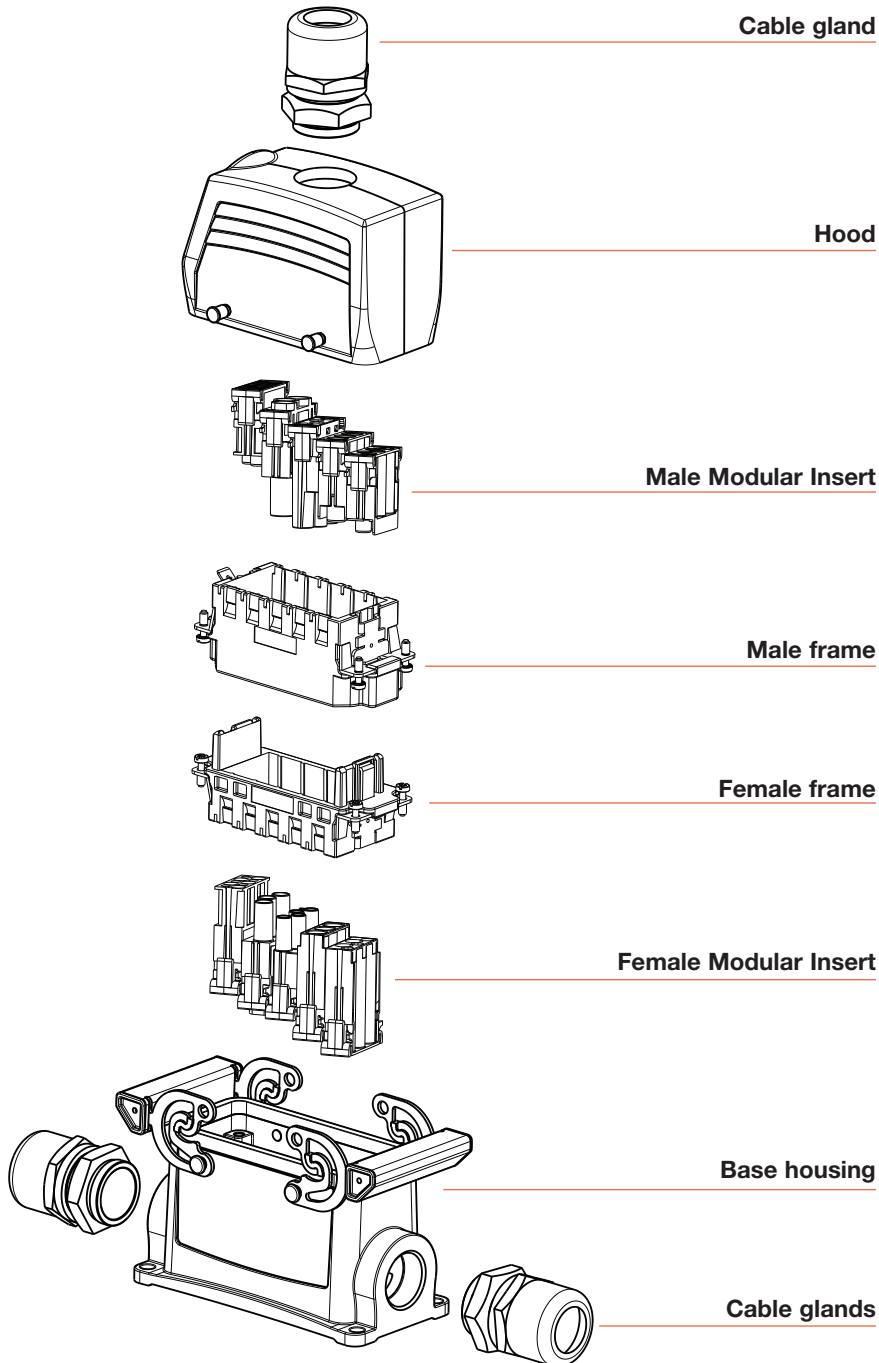

Overview of sizes 3, 4, 6, 8, 10, 12 – modular

Size

Hood, side cable entry

Hood, top cable entry

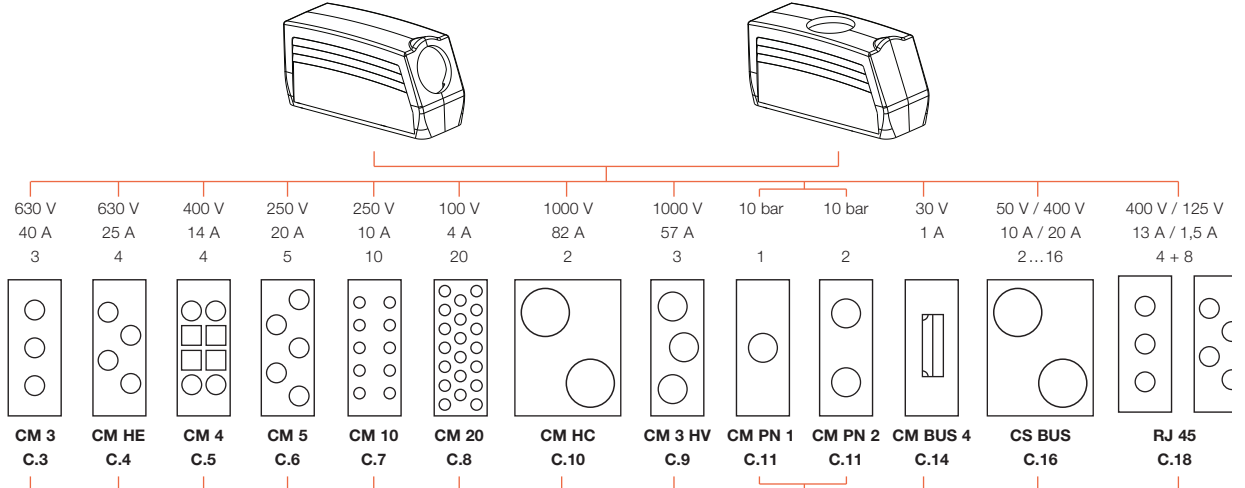

3

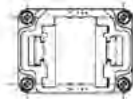

CF6 for 2 modules

4

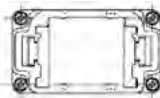

CF10 for 3 modules

6



CF16 for 5 modules

8



CF24 for 7 modules

10

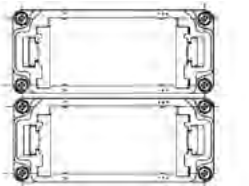

2 x CF16 for 10 modules

12

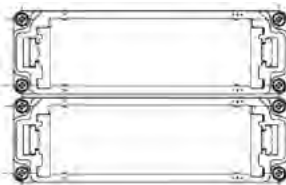

2 x CF24 for 14 modules

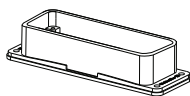

Bulkhead housing

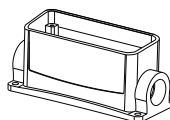

Base housing

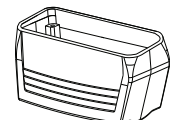

Coupling housing

Panel cut-out

Panel cut-out IP65/IP66

A

Size	Designation
Size 1 (IP65)	04A/07A
Size 2	10A/15A
Size 3	06B/16D
Size 4	10B/24D
Size 5	16A/25A
Size 6	16B/40D

Size	Designation
Size 7	32A
Size 8	24B/64D
Size 9	48A
Size 10	32B
Size 12	48B
HQ	

Panel cut-out IP68

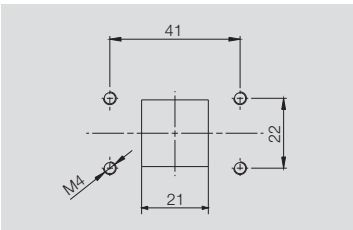
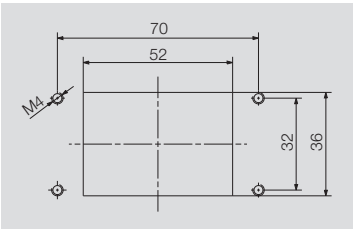
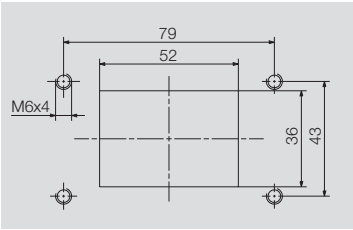
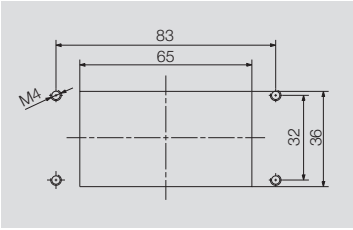
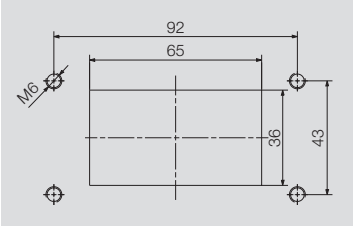
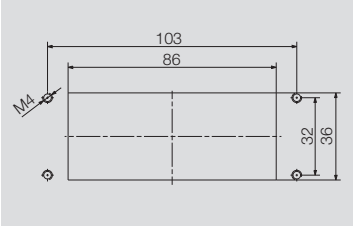
Size	Designation
Size 1 HA3	
Size 3 HB6/M4	
Size 3 HB6/M6	
Size 4 HB10/M4	
Size 4 HB10/M6	
Size 6 HB16/M4	

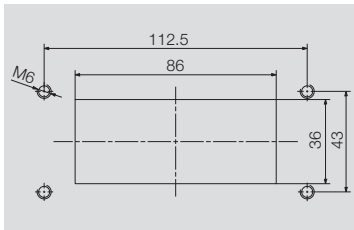
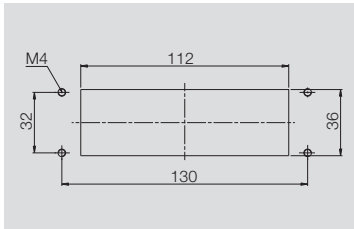
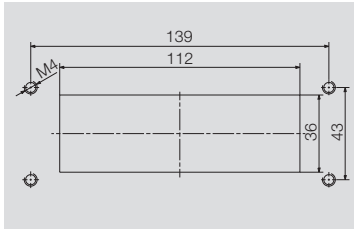
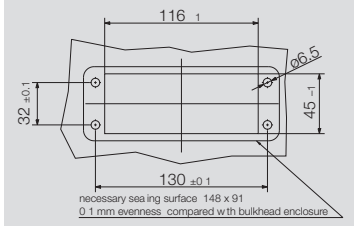
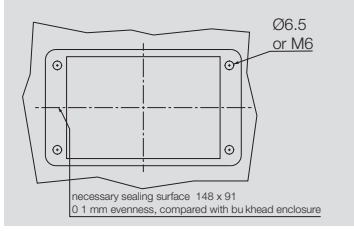



Size	Designation
Size 6 HB16/M6	
Size 8 HB24/M4	
Size 8 HB24/M6	
Panel cut-out IP68 XXL	
Size 8 HB24 XXL	
Size 12 HB48 XXL	

IP class of protection to DIN EN 60529

The class of protection is indicated by a code consisting of the two letters IP and two digits representing the class of protection.

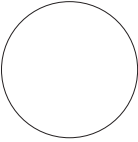
Example: **I P 6 5**
 | |
 2nd digit: protection from liquids
 1st digit: protection from solid bodies

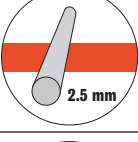
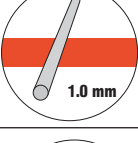
Protection against intrusion of external particle matter (1st digit)

Digit		
0		No protection
1		Protection against ingress of large solid bodies with diameter > 50 mm. (Protection to prevent dangerous parts being touched with the back of the hand.)
2		Protection against ingress of large solid bodies with diameter > 12.5 mm. (Protection to prevent dangerous parts being touched with the fingers.)
3		Protection against ingress of large solid bodies with diameter > 2.5 mm. (Protection to prevent dangerous parts being touched with a tool.)
4		Protection against ingress of large solid bodies with diameter > 1 mm. (Protection to prevent dangerous parts being touched with a piece of wire.)
5		Protection against harmful deposits of dust, which cannot enter in an amount sufficient to interfere with satisfactory operation.
6		Complete protection against ingress of dust.

Protection against penetration of liquids (2nd digit)

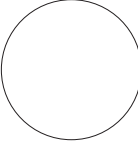
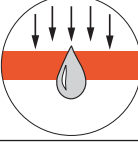
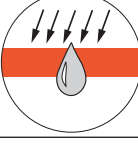
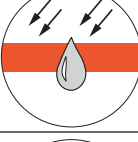
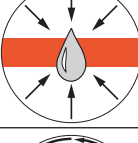
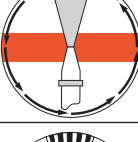
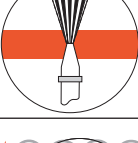
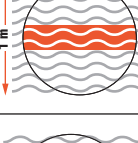
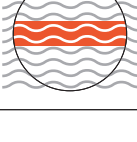
Digit		
0		No protection
1		Protection against drops of condensed water falling vertically.
2		Protection against drops of liquid falling at an angle of 15° with respect to the vertical.
3		Protection against drops of liquid falling at an angle of 60° with respect to the vertical.
4		Protection against liquids splashed from any direction.
5		Protection against water jets projected by a nozzle from any direction.
6		Protection against water from heavy sea on ships' decks.
7		Protection against immersion in water under defined conditions of pressure and time.
8		Protection against indefinite immersion in water under defined conditions of pressure (which must be agreed between manufacturer and user and must be more adverse than number 7).

Class of protection to NEMA

National Electrical Manufacturers Association NEMA 250-1991

Digit

Type 1

Housing primarily for use in inside rooms. Protects from penetration of solid bodies.

Type 2

Housing primarily for use in inside rooms. Protects from penetration of solid bodies and water.

Type 3

Housing primarily for use in inside rooms. Protects from penetration of rain and snow, dust and damage through ice formation.

Type 3R

Housing primarily for use in inside rooms. Protects from rain and snow as well as damage through ice formation.

Type 3S

Housing primarily for use in inside rooms. Protects from rain, snow and foreign bodies. External mechanisms can be operated despite ice formation.

Type 4

Housing for inside and outside rooms. Protects from rain, foreign bodies, water spray and water jets as well as damage through ice formation on the outside of the housing.

Type 4X

Housing for inside and outside rooms. Protects from corrosion, rain, foreign bodies, water spray and water jets as well as damage through ice formation on the outside of the housing.

Type 6

Housing for inside and outside rooms. Protects from water jets as well as penetration of water when submerged; protects from damage through ice formation on the outside of the housing.

Digit

Type 12

Housing for use in inside rooms. Protects from dust deposits and non-corrosive dripping liquids.

Type 13

Housing for use in inside rooms. Protects from dust deposits, water spray, oil and non-corrosive coolants.

RockStar® Housing types

Housing IP65/IP66 / NEMA Type 4X



Weidmüller has further developed its IP65/IP66 housing. The result is an industrial housing of a new design that also has the properties corrosion resistance and long service life. These new HDC industrial housings even surpass our previous HDC stainless steel housings in all respects. All operation elements are made of stainless steel. A high-quality, multistage surface sealing provides safety for years. Good isn't good enough for us. That's why Weidmüller discontinued the HDC stainless steel series and why you should use our new IP65/IP66 housing.

Applications:

- General mechanical engineering
- Conveying equipment and plant engineering
- Packaging machines
- Lighting and stage equipment
- Fairground rides
- Process engineering
- Transport and traffic engineering

Features:

- Tightness at least IP65/IP66 to EN 60529:1991 + A1:2000
- Tightness NEMA Type 4X
- Scratch-resistant, corrosion-proof, long-lasting

Design:

- Cast aluminium alloy
- 2 versions, standard and high
- Multistage surface coating
- Color: gray RAL 9006

Fastening systems:

- Clamp lock in different versions of rustproof stainless steel

HQ Series Housings, IP65/IP66 / NEMA Type 4X



Our comprehensive HQ line of connectors features an extremely compact housing in Weidmüller's IP65/IP66-designed housing series. These products, with their corrosion resistance and durability, are more ready than ever for industrial demands and are particularly suited for the materials handling sector. The HQ housing series plays a particularly important role for connecting motor starters and frequency converters.

HQ housings are available in a metal version or a plastic design offering extreme flexibility.

Applications:

- General machine construction
- Materials handling and systems engineering
- Packaging machines
- Decentralized automation

Features:

- Permeability: at least IP65/IP66, acc. to EN 60529: 1991 +A1:2000
- Permeability: NEMA Type 4X
- Complies with the VDE requirements, fulfils the DESINA standard
- Scratch-proof, corrosion resistant, durable

Design:

- Die cast aluminium, nickel-plated, multi-layer surface coating
- Polycarbonate, color: gray RAL 7032
- Two different shapes each: straight or angled cable outlet

Fastening systems:

- Clamping closure mechanism made of rust-free stainless steel

Housing IP68 – the highest degree of sealing



The IP68 housings have been developed for use under extreme environmental conditions. The high class of protection guarantees trouble-free operation in use on vehicles and under tough climatic conditions. If you want to protect your delicate interfaces from EMC emissions, these connectors are the right choice for you.

Applications:

- Transport and traffic engineering
- Extreme requirements on the class of protection

Features:

- Tightness IP68 / 5 bar to EN 60529 (1991) + part A1 (2000)
- Scratch-resistant, corrosion-proof, long-lasting

Design:

- Cast aluminium alloy
- 2 versions, standard and high
- Surrounding metal collar on housing
- Shielded versions for EMC protection
- Robust powder coating
- Color: black RAL 9005

Fastening systems:

- Screw fastening

Fastening systems

A

One longitudinal locking clamp on housing bottom



- Manual operation – no tools required
- 2 locking points – along the longitudinal axis
- Particularly suitable for row connection
- Fastening system of rustproof stainless steel

One central locking clamp on housing top



- Manual operation – no tools required
- 2 locking points along the transverse axis
- Easily accessible from above where space is limited
- Fastening system of rustproof stainless steel

Two transverse locking clamps on housing bottom



- Manual operation – no tools required
- 4 locking points – good sealing effect
- Easily accessible with cable entry pointing upwards
- Particularly suitable for row connection
- Fastening system of rustproof stainless steel

Screw fastening



- Operation with screwdriver
- Highly effective sealing
- 2 locking points along the longitudinal axis
- Easily accessible from above where space is limited
- Particularly suitable for row connection on all sides
- Stainless steel screws

Two transverse locking clamps on housing top



- Manual operation – no tools required
- 4 locking points – good sealing effect
- Easily accessible with cable entry pointing upwards
- Particularly suitable for row connection
- Fastening system of rustproof stainless steel

Part codes for inserts and covers

A

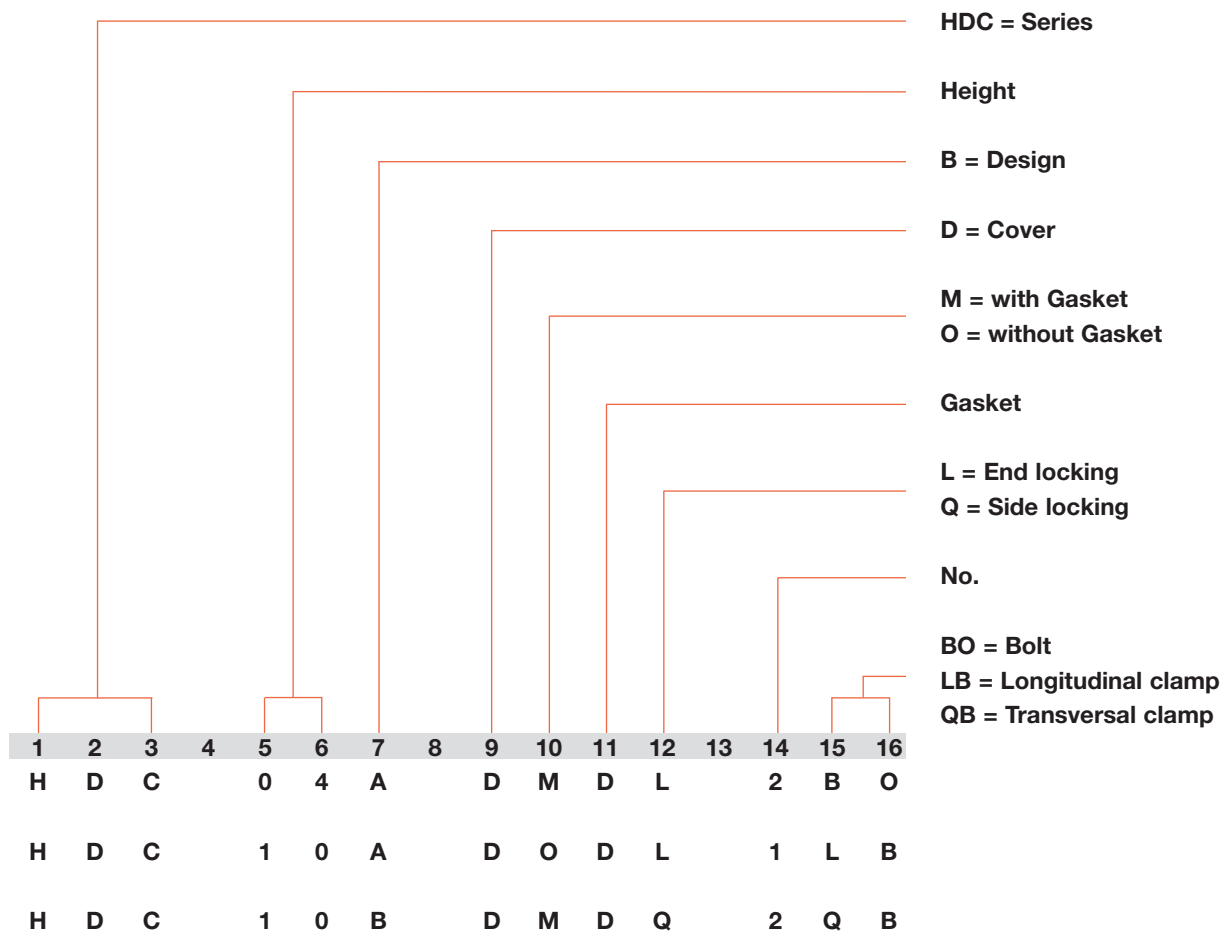
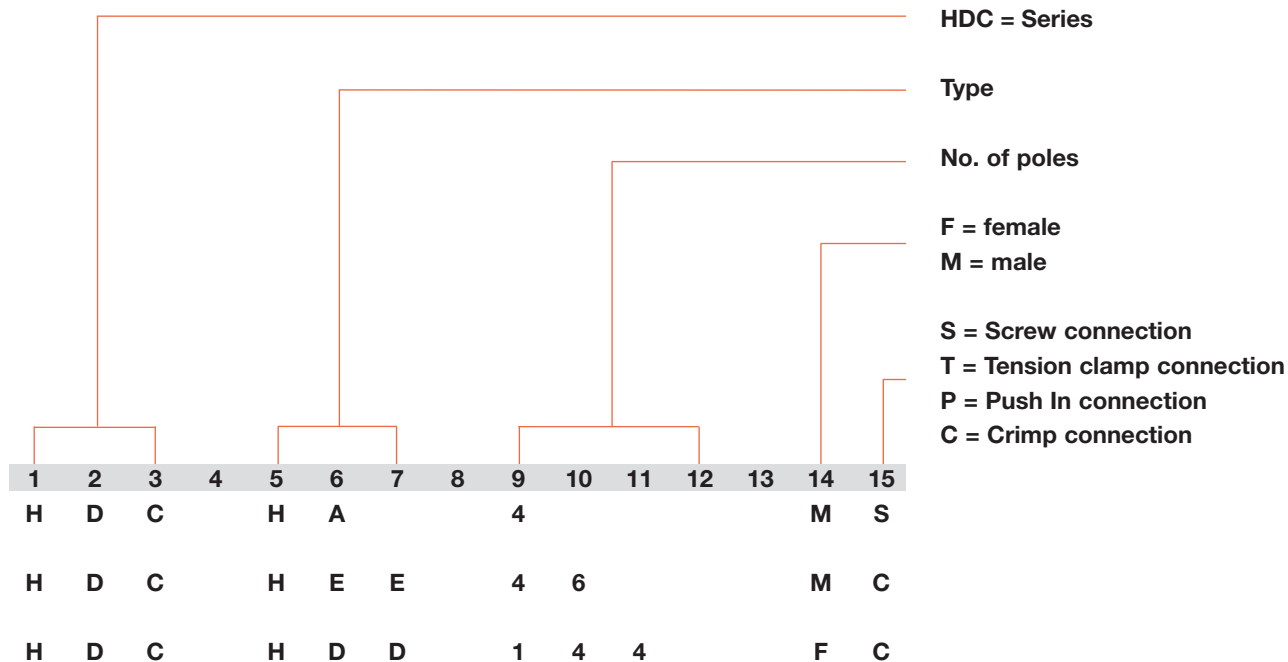

Part codes for housings

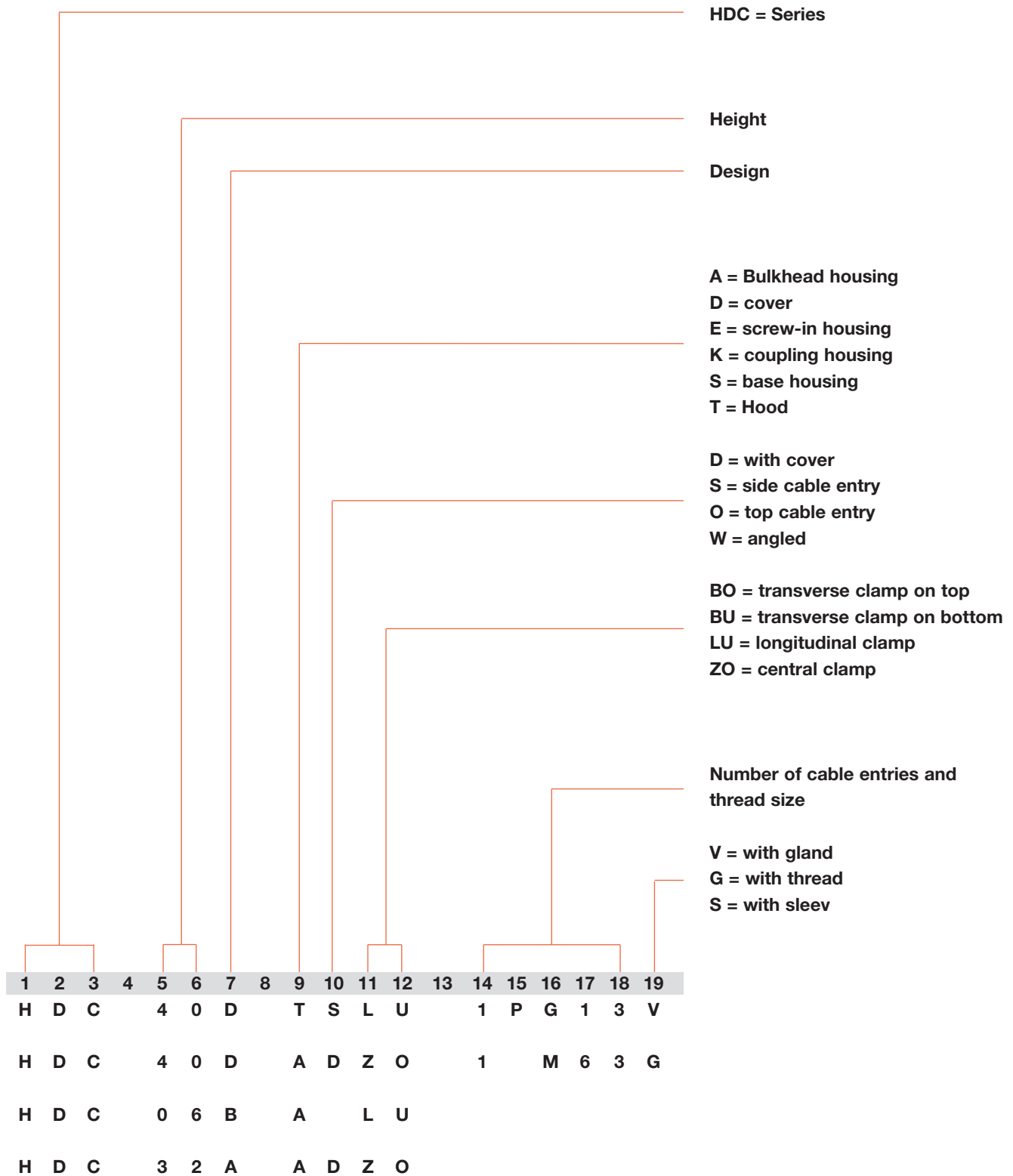

Connection systems

A

Weidmuller offers RockStar® connectors with five different connection systems

There are five common types of connection: tension clamp connection, screw connection, crimping, axial screw connection and push-in technology.

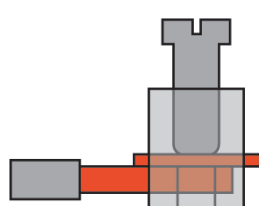

Screw connection

Screw connection systems are easy to handle and are known all over the world; this is an important point to consider for mounting and maintenance tasks which are spread throughout the world. Screw connections which

are based on a clamping-type body offer a gas-tight, vibration-proof connection for connected wires. They also feature excellent contact force. This system is thus perfectly suited for use in corrosive environments. The passivated silver surfaces ensure even more resistance against corrosion. The Weidmuller clamping-style body is perfectly suited for connecting solid-core and flexible stranded conductors. A wire-protection frame ensures that finely-stranded wires will not splice off.

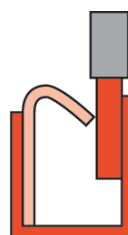

Push-In connection technology

With the **Push-In connection system**, the stripped solid-core conductor is simply inserted into the terminal point until it butts against the end stop. And then its ready. No tool is required and the result is a reliable,

vibration-resistant and gas-tight connection. Even flexible conductors with crimped wire end ferrules or ultrasonic-welded conductors can be connected without any problems. A stainless steel compression spring, which is fitted in a separate housing, guarantees a high contact force between the conductor and the current bar (tin-plated copper). The pull-out force for this system is even higher than that for the tension clamp system. Spring and conductor stops in a steel housing ensure optimum connection conditions and a guide for the screwdriver needed to detach the conductor.

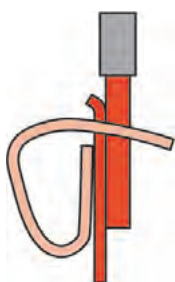

Tension clamp connection

The **Weidmuller tension clamp system** functions similarly to the tried-and-tested clamping yoke. Here again, the mechanical and electrical functions are kept separate. The tension spring made from high-quality rustproof and acid-proof steel pulls

the conductor against the tin-plated copper current bar. Treating the copper in this way ensures low contact resistance and high corrosion resistance. The compensating effect of the tension spring ensures a secure contact for the lifetime of the terminal.



In the **crimping** method, the wires are fed into a metal sleeve, which is then squeezed together with a special tool. The connection is now corrosion and vibration proof. The contacts can be crimped on the conductor outside of the connector and then inserted into the connector.

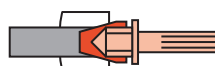

The advantage of the axial screw connection

is the small space taken up by the contact. The axial screw

connection is also extremely easy to use. To make up the connection, the tool and conductor are held in a line. Just three steps are needed for a secure connection: strip the conductor, insert the wire into the contact chamber, screw in the contact – that's all!

Of course, all of Weidmuller's wire connection systems are gas-tight.

Crimp contacts

Whereas the contacts for screw, axial screw, tension clamp and Push In connections are already built in, the customer can choose the appropriate contact for a crimp connection.



The contacts are the heart of a plug-in connector. They represent the actual connection between two conductors. Two kinds of contact are necessary: pins and sockets (male and female). The pin conducts the electrical current on its outer surface and is introduced into the socket, which conducts the electrical current on its inner surface. Heavy-duty connectors have copper alloy contacts and the contact surfaces are plated with gold or silver: silver improves conductivity, gold is corrosion-proof.

Crimp contacts are available in turned, solid form.

Selection of silver or gold-plated contacts

When using plug-in connectors under standard conditions, the resistance between the contacts has little effect. Even heavily corroded silver-coated contact pins and sockets do not exhibit any contact problems.

The situation is different where there are very small currents in extreme applications such as those in electroplating shops, tunnels or in cellulose processing. The silver oxide layer on the surface of the contacts forms an electrical resistance with capacitive, inductive and ohmic components. As a result, the original signal is distorted so much that the recipient is unable to detect it properly and interprets it incorrectly. This results in faults and, indirectly, to damage to machines and processes. Gold-plated contacts should be used in such cases.

The rule of thumb is: use gold-coated contacts for currents < 5 mA and voltages of up to 5 V.

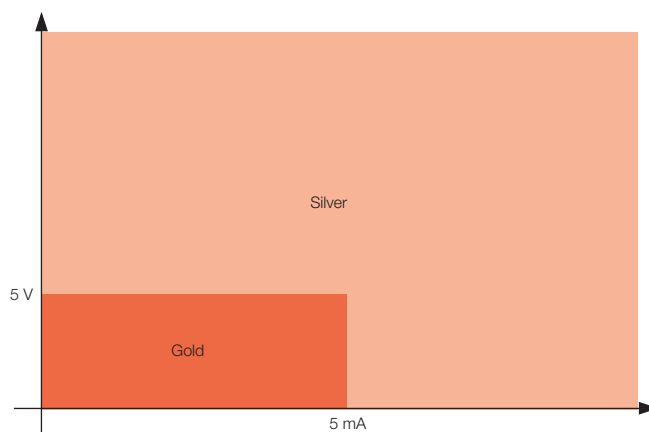

Electrical data

A

Design of clearances and creepage distances in electrical equipment

General

Since April 1997 the sizing of clearances and creepage distances has been covered by DIN VDE 0110, part 1 "Insulation coordination for electrical equipment in low-voltage systems". DIN VDE 0110, part 1 contains the modified edition of IEC Report 664-1 (see also IEC 664-1/Oct 1992). Since April 2003, the rules of DIN EN 60664-1 / 11.03 in conjunction with DIN 61984 / 09.02 apply to the dimensioning of clearances and creepage distances.

The design data resulting from these provisions is – if applicable – specified in this catalog for each product.

For the design of clearances and creepage distances, application of the regulations for insulation coordination produces the following interrelationships:

Clearances

Clearances are rated in accordance with the following factors:

- Anticipated surge
rated impulse withstand voltage
- Used
surge protection precaution
- Measures to prevent pollution
pollution severity

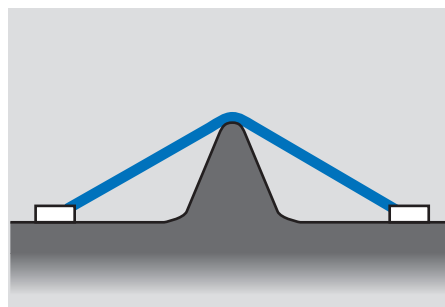

Creepage distances

Creepage distances are rated in accordance with the following factors:

- Planned
rated voltage
- Insulation materials used
insulation group
- Measures to prevent pollution
pollution severity

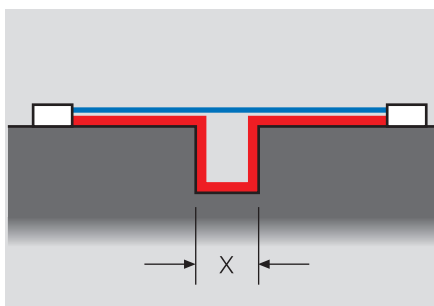
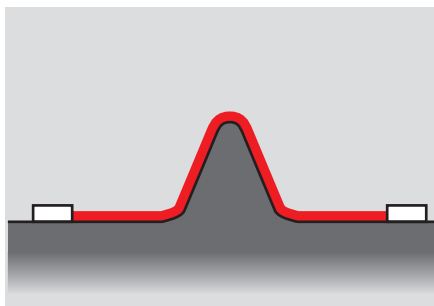

Slots are taken into account when measuring creepage distances if their minimum width X is dimensioned according to the following table:

Pollution severity	Minimum width X in mm
1	0.25
2	1.0
3	1.5
4	2.5

If the associated clearance in air is less than 3 mm, the minimum slot width can be reduced to 1/3 of the clearance.

Influencing factors:

Rated impulse withstand voltage

The rated impulse withstand voltage is derived from:

- **Phase-to-ground voltage** (the nominal voltage of the network, taking all networks into account)
- **Surge category**

The surge categories are defined

in accordance with international standard DIN EN 60664-1 (for electrical equipment fed directly from the low voltage network).

Surge category I

- Equipment that is intended to be connected to the permanent electrical installation of a building. Measures to limit transient surges to the specific level are taken outside the equipment, either in the permanent installation or between the permanent installation and the equipment.

Surge category II

- equipment to be connected to the permanent electrical installation of a building e.g. household appliances, portable tools and similar loads.

Surge category III

- equipment that is part of the permanent electrical installation and other equipment where a higher degree of availability is expected e.g. distribution boards, circuit-breakers, wiring systems (IEV 826-06-01, including cables, busbars, junction boxes, switches, power sockets) in the permanent installation, and equipment for industrial use and some other equipment, e.g. stationary motors with permanent connections to the permanent installation.

Surge category IV

- Equipment for use at or in the proximity of the incoming supply point of the electrical installations of buildings upstream of the main distribution board e.g. electricity meters, circuit-breakers and ripple control units.

Pollution severity categories:

Pollution severity category 1

- No pollution, or only dry, non-conductive pollution that has no influence.

Pollution severity category 2

- Non-conductive pollution only; occasional condensation may cause temporary conductivity.

Pollution severity category 3

- Conductive pollution, or dry, non-conductive pollution that is liable to be rendered conductive through condensation.

Pollution severity category 4

- Contamination results in constant conductivity, e.g. caused by conductive dust, rain or snow.

The dimensioning of clearances and creepage distances, and hence the rating data for electromechanical products (terminals, terminal strips, PCB terminals and plug-in connectors) is based on pollution severity 3 and surge category III, taking account of all network types.

Table 1: Three-phase 4 or 3-conductor a.c. systems

Nominal voltage of power supply systems [V]	for conductor-cond. insulat.	for conductor-ground insulation	
	all Systems [V]	3-phase 4-conductor systems with grounded neutral cond. [V]	3-phase 4-conductor systems ungrounded or cond. grounded [V]
60	63	32	63
110			
120	125	80	125
127			
150	160	–	160
208	200	125	200
220			
230	250	160	250
240			
300	320	–	320
380			
400	400	250	400
415			
440	500	250	500
480			
500	500	320	500
575	630	400	630
600	630	–	630
660			
690	630	400	630
720			
830	800	500	800
960	1000	630	1000
1000	1000	–	1000

Electrical data

A

Design of clearances and creepage distances in electrical equipment, influencing factors:

Rated voltage

The rated voltage is derived from the nominal voltage of the power supply and the corresponding network type.

Single-phase

2- or 3-wire AC or DC systems

Rated voltage of the power supply (mains) ¹⁾	Voltages for table 4	
	For insulation phase-to-phase ¹⁾	For insulation phase-to-ground ¹⁾
	All systems	3-wire systems, neutr. point grounding
V	V	V
12.5	12.5	–
24 / 25 30	25 32	–
42 / 48 / 50 ^{*)} 60	50 63	–
30-60	63	32
100 ^{*)}	100	–
110 / 120 150 ^{*)}	125 160	–
220	250	–
110-220 120-240	250	125
300 ^{*)}	320	–
220-440	500	250
600 ^{*)}	630	–
480-960	1000	500
1000 ^{*)}	1000	–

3-phase

3- or 4-wire AC systems

Rated voltage of the power supply (mains)	Voltages for table 4		
	For insulation phase-to-phase	For insulation phase-to-ground	
	All systems	3-phase 4-wire systems with grounded neutral wire ²⁾	3-phase 3-wire systems ungrounded ¹⁾ or phase-grounded
V	V	V	V
60	63	32	63
110/120/127 150 ^{*)}	125 160	80 –	125 160
208	200	125	200
220/230/240 300 ^{*)}	250 320	160 –	250 320
380/400/415 440	400 500	250 250	400 500
480/500 575	500 630	320 400	500 630
600 ^{*)}	630	–	630
660/690 720/830	630 800	400 500	630 800
960 1000 ^{*)}	1000 1000	630 –	1000 1000

1) Phase-to-ground insulation levels for ungrounded or impedance-grounded systems are equal to those of phase-to-phase because the operating voltage to ground of any phase can, in practice, reach full phase-to-phase voltage. This is because the actual voltage to ground is determined by the insulation resistance and capacitive reactance of each phase to ground; thus, a low (but acceptable) insulation resistance of one phase can ground it and raise the other two to full phase-to-phase voltage to ground.

2) For electrical equipment for use in both 3-phase 4-wire and 3-phase 3-wire supplies, grounded and ungrounded, use the values for 3-wire systems only.

) It is assumed that the rated voltage of the electrical equipment is not lower than the nominal voltage of the power supply.

^{*)} Because of the common changes, the meaning of the ^{*)} symbol has not been used in table 1; i.e. the / symbol indicates a 4-wire 3-phase distribution system. The lower value is the phase-to-neutral voltage, while the higher value is the phase-to-phase voltage. Where only one value is indicated, it refers to 3-wire 3-phase systems and specifies the value phase-to-phase. The values given in table 1 are still taken into account in tables 3a and 3b by the ^{*)} symbol.

Insulating material

The insulating materials are subdivided into four groups according to their CTI (Comparative Tracking Index):

Insulating material

I	600 ≤ CTI
II	400 ≤ CTI < 600
III a	175 ≤ CTI < 400
III b	100 ≤ CTI < 175

The comparative tracking index must be determined according to DIN IEC 112/VDE 0303 part 1 on the basis of specially prepared samples with test solution A.

The **derating curve** shows which currents may flow continuously and simultaneously via all possible connections when the component is subjected to various ambient temperatures below its upper limit temperature.

The **upper limit temperature** of a component is the rated value determined by the materials used. The total of the ambient temperature plus the temperature rise caused by the current load (power loss at contact resistance) may not exceed the upper limit temperature of the component, otherwise it will be damaged or even completely ruined. The current-carrying capacity is hence not a constant value, but rather decreases as the component ambient temperature increases. Furthermore, the current-carrying capacity is influenced by the geometry of the component, the number of poles and the conductor(s) connected to it.

The current-carrying capacity is determined empirically according to DIN IEC 60512-3. To do this, the resulting component temperatures t_{b1} , t_{b2} ... and the ambient temperatures t_{u1} , t_{u2} are measured for three different currents I_1 , I_2 , I_3 The values are entered on a graph with a system of linear coordinates to illustrate the relationships between the currents, the ambient temperatures and the temperature rise in the component.

The **loading currents** are plotted on the y-axis, the **component ambient temperatures** on the x-axis. A line drawn perpendicular to the x-axis at the upper limit temperature t_g of the component completes the system of coordinates. The associated average values of the temperature rise in the component, $\Delta t_1 = t_{b1} - t_{u1}$, $\Delta t_2 = t_{b2} - t_{u2}$, ... are plotted for every current I_1 , I_2 , ... to the left of the perpendicular line. The points generated in this way are joined to form a roughly parabolic curve.

As it is practically impossible to choose components with the maximum permissible contact resistances for the measurements, the base curve must be reduced. Reducing the currents to 80% results in the **“derating curve”** in which the maximum permissible contact resistances and the measuring uncertainties in the temperature measurements are taken into account in such a way that they are suitable for practical applications, as experience has shown. If the derating curve exceeds the currents in the low ambient temperature zone, which is given by the current-carrying capacity of the conductor cross-sections to be connected, then the derating curve should be limited to the smaller current in this zone.

Base curve

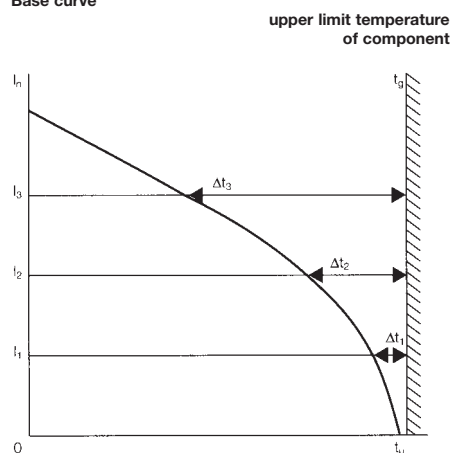

t_g = upper limit temperature of component
 t_u = ambient temperature
 I_n = current

Derating curve

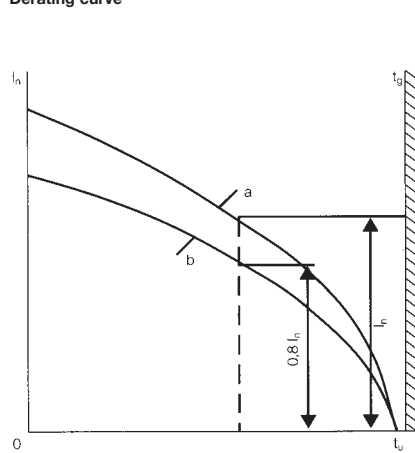

t_g = upper limit temperature of component
 t_u = ambient temperature
 I_n = current
 a = Base curve
 b = Reduced base curve (derating curve)

Chemical resistance

Chemical resistance of inserts (material PC, 20 % GF)

Acetone	+
Ammonia, aqueous	-
Petrol	+
Benzine	+
Diesel oil	-
Acetic acid, concentrated	+
Aqueous potassium hydroxide	-
Methanol	-
Engine oil	-
Alkaline solution, diluted	+
Chlorinated hydrocarbons	-
Use in open air	-

Chemical resistance of standard housing seal (material NBR)

Acetone	-
Drilling oil	+
Diesel	+
Ethyl alcohol	+
Gear oil	+
Hydraulic oil	+
Cooling lubricant	+
Petrol	+
Sweat	+
High-octane petrol	-
Water	+

+ resistant

- partially resistant

o not resistant

Tightening torques and recommended screw bit size

Screw size	Connector type	Dia. tightening torque in Nm	Recommended blade inserts and AF size for hexagon socket
M 2.5	S 6/6 and S 6/12 Clamping point		
	Signal contact	0.5 – 0.55	0.6 x 3.5 mm ± Gr. PZ0
M 3	Screw insert		
	HA 3; HA 4	0.5 – 0.55	0.6 x 3.5 mm ± Gr. PH0
M 3	PE terminal		
	HQ 5; HQ 7	0.5 – 0.55	0.6 x 3.5 or 0.8 x 4 mm
M 3	Screw insert		
	HA 10 - HA 48	0.5 – 0.55	0.6 x 3.5 mm ± Gr. PH0
M 3	Screw insert HE series		
	HVE series		
	Fastening screws	0.5 – 0.55	0.6 x 3.5 mm ± Gr. PZ0
	Guide pin	0.5 – 0.55	0.6 x 3.5 mm ± Gr. PZ0
	Guide bush	0.5 – 0.55	0.6 x 3.5 mm ± Gr. PZ0
	Coding pins	0.4 - 0.5	0.6 x 3.5 mm ± Gr. PZ0
M 4	PE terminal		
	HA series	1.2 - 1.5	0.6 x 3.5 or 0.8 x 4 mm ± Gr PH1
	HE series	1.2 - 1.5	0.6 x 3.5 or 0.8 x 4 mm ± Gr PH1
	HEE PE	1.2 - 1.5	0,6 x 3,5 or 0,8 x 4 mm ± Gr PH1
	HVE series	1.2 - 1.5	0.6 x 3.5 or 0.8 x 4 mm ± Gr PH1
	HD series	1.2 - 1.5	0.6 x 3.5 or 0.8 x 4 mm ± Gr PZ1
	HDD series	1.2 - 1.5	0.6 x 3.5 or 0.8 x 4 mm ± Gr PZ1
M 4	Screw insert		
	HSB series	1.2 - 1.5	0.6 x 3.5 or 0.8 x 4 mm ± Gr PZ1
M 5	PE terminal		
	HSB series	2 - 2.5	1 x 5.5 mm ± Gr. PZ2
M 7 x 0.75 S 4	Axial connection of power contacts	1.1 – 1.7	SW 2
M 4	S 4 PE screw via male contact	1.2 – 1.5	SD 0.6 x 3.5 mm
M 3	S 4 PE Schraub via female contact	0.5 – 0.55	SD 0.6 x 3.5 mm
M 7 x 0.75	S 6/6 Axial connection of power contacts	6 – 8	SW 4
M 8 x 0.75	S 6/12 Axial connection of power contacts	1.1 – 1.7	SW 2
M 10 x 1	S 4/0 Axial connection of power contacts	2 – 3	SW 3

Increasing the tightening torque does not improve the contact resistance. The stated torque settings offer optimal mechanical, thermal and electrical conditions. Exceeding the recommended values may even damage the conductor and terminal.

Clamping range and ferrules

Type of connection	Series	HA	HE	HVE
Screw	Clamping range [mm ²]	0.5 – 2.5	0.5 – 2.5	0.5 – 2.5
	Clamping range [AWG]	20 – 12	20 – 14 (12) ³⁾	20 – 14 (12) ³⁾
	Ferrules with collars	H0.5/14 – H2.5/14	H0.5/14 – H2.5/14 ²⁾	H0.5/14 – H2.5/14 ²⁾
		H0.5/16 – H2.5/16	H0.5/16 – H2.5/16 ²⁾	H0.5/16 – H2.5/16 ²⁾
	Ferrules without collars	H0.5/10 – H2.5/10	H0.5/10 – H2.5/10	H0.5/10 – H2.5/10
	Crimp tool	PZ4 ²⁾ , PZ6, PZ6/5	PZ4 ²⁾ , PZ6, PZ6/5	PZ4 ²⁾ , PZ6, PZ6/5
			PZ6 Hex ²⁾	PZ6 Hex ²⁾
	Screwdriver	SDK PH0 SD 0.5x 3.0	SDK PH0 SD 0.5x 3.0	SDK PH0 SD 0.5x 3.0
Tightening torque	0.5 Nm	0.5 Nm	0.5 Nm	
Tension clamp	Clamping range [mm ²]	0.5 – 1.5 ⁴⁾	0.25 – 2.5	0.5 – 2.5
		2.5 solid core ⁴⁾		
	Clamping range [AWG]	20 – 14 ⁴⁾	20 – 14	20 – 14
	Ferrules with collars	H0.5/14 – H1.5/14 ⁴⁾	H0.5/14 – H2.5/14 ²⁾	H0.5/14 – H2.5/14 ²⁾
		H0.5/16 – H1.5/16 ⁴⁾		
	Ferrules without collars	H0.5/10 – H1.5/10 ⁴⁾	–	–
	Crimp tool	PZ4, PZ6, PZ6/5	PZ4 ¹⁾ , PZ6, PZ6/5	PZ4 ¹⁾ , PZ6, PZ6/5
Screwdriver	SD 0.5x 3.0	SD 0.6x 3.5	SD 0.6x 3.5	
Crimp	Clamping range [mm ²]	0.5 – 4	0.5 – 4	–
	Clamping range [AWG]	20 – 12	20 – 12	–
	Removal tool	HDC-DW-M4	HDC-DW-M4	–
Removal Tool HE		Removal Tool HE	–	
Push-In	Clamping range [mm ²]	–	solid 0.75 – 2.5 mm ² flexible with ferrule 0.5 – 2.5 mm ²	–
		–	20 – 12	–
		–	H0.5/14 – H1.5/14	–
	Ferrules with collars	–	H0.5/16 – H1.5/16	–
		–	H0.75/18 – H2.5/18 ²⁾	–
		–	H0.5/10 – H2.5/10 ²⁾	–
	Ferrules without collars	–	H1.5/12 – H2.5/12 ²⁾	–
Ferrules crimped with	–	PZ4, PZ6, PZ6/5, PZ6 Hex	–	
PE contact	Clamping range [mm ²]	0.5 – 4.0	0.5 – 4	0.5 – 4
		0.5 – 2.5 flexible		
	Clamping range [AWG]	20 – 12	20 – 12	20 – 12
	Ferrules with collars	H0.5/16 – H2.5/16	H0.5/16 – H4/16	H0.5/16 – H4/16
	Ferrules without collars	H0.5/10 – H2.5/10	H0.5/10 – H4/10	H0.5/10 – H4/10
	Ferrules crimped with	PZ4 ²⁾ , PZ6, PZ6/5	PZ4, PZ6, PZ6/5, PZ6 Hex	PZ4, PZ6, PZ6/5, PZ6 Hex
			PH 1	PH 1
Tightening torque	1.2 Nm	1.2 Nm	1.2 Nm	

¹⁾ PZ4 crimping tools should not be used with max. wire

²⁾ the 2.5mm² wire must be inserted with some force

³⁾ some force must be used to insert the max. AWG wire, depending on insulation thickness

⁴⁾ only by tilting the screwdriver can the clamping point be opened all the way

Safety information / standards

Pay attention to the following safety advice:

- Never plug or unplug connectors under load or in operation.
- We can only guarantee the technical and electro-technical characteristics promised in this catalog if all the components were supplied by Weidmüller.

The following standards apply in the vicinity of heavy-duty connectors:

- DIN EN 60664-1 or IEC 60664-1:
Insulation coordination for equipment within low-voltage systems; principles, requirements and tests (replaces DIN VDE 0110-1)
- DIN EN 61984 or IEC 61984:
Plug-in connectors – safety requirements and tests
- DIN EN 175301-801:
Detail Specification: High-density rectangular plug-in connectors, round removable crimp contacts; (replaces DIN 43652)
- DIN EN 60352 or IEC 60352:
Solderless connections
- DIN EN 60529 or IEC 60529:
Classes of protection provided by enclosures (IP code)
- DIN VDE 0870:
Electromagnetic influence
- DIN EN 60999-1:
Connecting devices, safety requirements for screw terminal connections and screwless terminal connections for electrical copper conductors ...
- DIN 40050-9:
Road vehicles; classes of protection (IP-code); ...
- DIN EN 60664-1:
Plug-in connectors – safety requirements and tests

