

Loop Powered, Isolators

TWI-1 Single Channel TWI-2 Dual Channel



The TWI-1 and TWI-2 are single and dual channel, loop powered isolators.

- Current or Voltage inputs
- Powered from 4-20mA output loop
- Highly accurate ($\pm 0.1\%$ of span)
- Front panel zero and span adjustment
- Complete Isolation
- Removable, screw-type, terminal blocks
- Compact metal housing



Australia

Weidmüller Pty Ltd.
43 Huntingwood Drive, Huntingwood
NSW 2148
Phone +61 (0) 2 9671 9999
Fax +61 (0) 2 9671 9900
info@weidmuller.com.au
www.mannseries.com

United Kingdom

Weidmüller Ltd.
1 Abbey Wood Road, Kings Hill
West Malling, Kent ME19 4YT
Phone +44 1732-877032
Fax +44 1732-873873
info@weidmuller.co.uk
www.weidmueller.com

Other countries

Weidmüller Interface GmbH & Co.
Postfach 3030
32720 Detmold
Phone +495231-14-0
Fax +495231-14-2083
info@weidmueller.com
www.weidmueller.com

Loop Powered, Isolators



Technical Specifications

Inputs	
Type	DC milliamp or voltage
Ranges	4-20mA or 0-10V
Input impedance	27Ω (4-20mA inputs) or ≥1MΩ (0-10V inputs)
Outputs	
Type	4-20mA loop powered
Ripple	less than 10mV peak to peak
Max loop load	$[(V_s - 12) / 0.02] \Omega$ (Typically 600Ω at 24Vdc)
Power Supply	
Type	12-45Vdc loop powered
Line voltage effect	less than 0.05% of span change for 10V change in supply over 12-45Vdc range
Adjustments	
Type	22-turn potentiometers
Span	±25% of nominal span
Zero	±25% of nominal span
General	
Linearity	±0.1% of span
Repeatability	±0.02% of span
Storage temperature	-25 to +70 °C
Operating temperature	-10 to 60 °C
Relative humidity	0-95% (non-condensing)
Temperature drift	±0.05% span per °C
Long term drift	< 0.1% per 10,000 hours
Input response	200mS (from 10% to 90% of span)
RFI Immunity	Less than 0.5% span error for 10V/m from 24MHz to 1000MHz
Insulation Co-ordination	
Ports	Input / Output / Case (for each channel)
Rated Insulation Voltage	300Veff
Overvoltage Category	III
Impulse Withstand	4kV (1.2 / 50)
Isolation	2 kV (between ports)
Environmental Conditions	
Operating temperature	0 to 60 °C
Storage temperature	-25 to +70 °C
Pollution Degree	2
Relative humidity	10-90% (non-condensing)
Housing	
Type	Dual DIN Rail Mount Aluminium Enclosure
Dimensions	See diagram
Weight	TWI-1 0.20 kg TWI-2 0.25 kg
Connection type	Plug in terminal blocks with screw connections
Approvals	Mark
TWI-1	E256486
TWI-2	E256486
	LV Directive EMC
Standard	
	CAN/CSA C22.2 No. 1010.1:92 UL61010-1: 2004
	EN50178:1998 BS EN 61326:1998 + A2

TWI-1 Connections

Terminal	Signal	
1	Signal +	Input
2	Not used	
3	Signal -	
4	Signal +	Output
5	Not used	
6	Signal -	
Case	Earthing is via a stud on lower side of case	

TWI-2 Connections

Terminal	Signal	
1	Signal +	Input Channel one
2	Signal -	
3	Signal +	Input Channel two
4	Signal -	
5	Signal +	Output Channel one
6	Signal -	
7	Signal +	Output Channel two
8	Signal -	
Case	Earthing is via a stud on lower side of case	

Dimension drawing

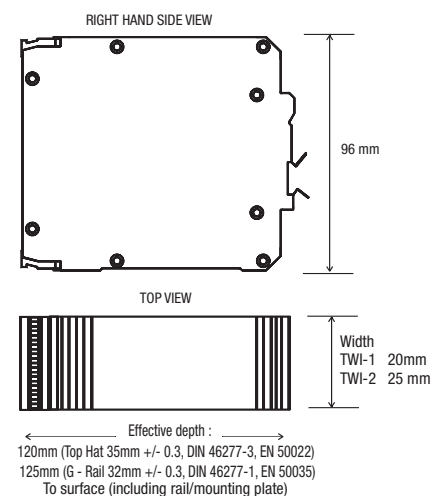

Ordering Information

	Single Channel	Dual Channel
4-20mA Input	TWI-1 4-20mA	TWI-2 4-20mA
0-10V Input	TWI-1 0-10V	TWI-2 0-10V
Type (Model Input)	Cat. No.	
TWI-1 4-20mA	7940010159	
TWI-2 4-20mA	7940010171	
TWI-1 0-10V	7940011660	
TWI-2 0-10V	7940012011	