

## Multiplus Multi-Input Signal Converter/Displays

### AI8 8-Channel Current/Voltage Input Module RI4 4-Channel Temperature (RTD) Input Module



- Calculate, monitor and display any input or combination of inputs in engineering units
- Up to 4 alarm channels
- Up to 2 analogue outputs
- RS422/485 Modbus RTU Communications (compatible with most major industrial software packages)
- Includes configuration and DDE Client server software
- Built-in suite of single and multi-variable functions including linearisation, minimum, maximum, average, difference, sum and product
- AC or DC powered
- Fully Isolated
- Highly accurate
- PIN numbers protect instrument calibration and set-up



#### Australia

Weidmüller Pty Ltd.  
43 Huntingwood Drive, Huntingwood  
NSW 2148  
Phone +61 (0) 2 9671 9999  
Fax +61 (0) 2 9671 9900  
info@weidmuller.com.au  
www.mannseries.com

#### Other countries

Weidmüller Interface GmbH & Co.  
Postfach 3030  
32720 Detmold  
Phone +495231-14-0  
Fax +495231-14-2083  
info@weidmueller.com  
www.weidmueller.com

**Micromann Multiplus Series**

MultiPlus instruments allow multiple inputs, multiple outputs and multiple alarms to be processed simultaneously.



The units use a series of 'internal' variables that are calculated from the input values. These variables can be used for the alarms, for output as analogue/digital signals or for the display.

All MultiPlus products are constructed using a common platform with many common features. The differences between the models are:

- Housing (DIN Rail)
- Input conditioning circuit
- Software features for the input type

All units are programmable in plain English from the front panel keypad or via the digital communications port (if fitted).

**General Technical Data**

<b>Display</b>	
Type	Displays 'internal' variables and input values or input values only (in engineering units)
Format	2 line by 16 character alphanumeric backlit LCD display
Range	-99999 to +99999
Scaling	Anywhere within display limits
Units	58 pre-defined plus 4 user defined
Display scrolling	Manual or Automatic
Automatic scroll time	2 to 20 seconds
<b>'Internal' variables</b>	
Values	See individual inputs for available formulas
<b>Analogue outputs (optional)</b>	
Type	Proportional to any input or 'internal' variable
Format	Analogue current/voltage signal
Number of channels	0 or 2 (as ordered)
Current range	Inside the range 0.00 to 20.00mA
Voltage range	Inside the range 0.00 to 10.00V
Recommended minimum span	2mA or 1V
Accuracy	Better than ±0.05% of span at 25°C
Temperature drift	Better than ±0.01% of full range per °C
<b>Alarms</b>	
Type	Monitor any input or 'Internal' variable (see individual models for details of 'internal' variables)
Number of channels	1 (standard) or 4 (optional)
Contacts	SPDT relay contacts
Rating	3A at 240Vac or 30Vdc
<b>Digital Communications (optional)</b>	
Type	Serial communications
Protocol	Modicom Modbus RTU
Interface type	RS485 / RS422
Baud rate	4800 / 9600 / 19200
Parity	None
Slave ID	1 to 247
<b>Power Supply</b>	
Type	AC or DC powered
High voltage version	90-250Vac or 90-250Vdc
Low voltage version	20-35Vdc
<b>General</b>	
Storage Temp	-20 to +60°C
Operating Temp	0 to 50°C
Humidity	10 - 90% non condensing
<b>Insulation Co-ordination</b>	
Ports	Input Circuits, Relay Channel One, Relay Channel Two, Relay Channel Three, Relay Channel Four, Analogue Output Channel One, Analogue Output Channel two, Digital Communications Port; Power Supply / Case
Rated Insulation Voltage	300Veff
Overvoltage Category	III
Impulse Withstand	4kV (1.2 / 50)
Isolation	2 kV (between ports)
<b>Approvals</b>	
Both models	 E256486
DC Powered only	 LV Directive EMC
<b>Standard</b>	
	CAN/CSA C22.2 No. 1010.1:92 UL61010-1: 2004
	EN50178:1998 BS EN 61326:1998 + A2

**Connection details (DIN rail mount modules)**

Pin	Signal	
1 to 14 Input signals (see individual modules for detail)		
15	Signal +	Analogue output one (optional)
16	Current -	
17	Voltage -	
18	Signal +	Analogue output two (optional)
19	Current -	
20	Voltage -	
21	Neutral / -	Power supply
22	Live / +	
23	Not used	
24	Receive -	RS422/485* Output (* For RS485 output connect 24 & 27 and 25 & 26)
25	Receive +	
26	Transmit +	
27	Transmit -	
28	Not used	
29	Normally Closed	Alarm Channel One (standard)
30	Normally Open	
31	Common	
32	Normally Closed	Alarm Channel Two (optional)
33	Normally Open	
34	Common	
35	Normally Closed	Alarm Channel Three (optional)
36	Normally Open	
37	Common	
38	Normally Closed	Alarm Channel Four (optional)
39	Normally Open	
40	Common	

Note 1: Earthing is via a stud on the underside of the case  
 Note 2: Double grey lines indicate isolation between ports

## AI8 8 channel analogue input module/display

- Accept eight current/voltage signals
- Will power eight loop powered inputs
- All channels can be individually linearised
- Inbuilt math functions
- Bipolar inputs



AI8 - DIN rail mount module

### Technical Data

Inputs	
Type	Analogue Current/Voltage signals
Number of channels	8
Standard range limits	-20.00mA to +20.00mA or -10.00V to +10.00V (without recalibration)
Input impedance	22Ω (current inputs) 1MΩ (voltage inputs)
Linearisation	x, √x, x <sup>2</sup> , x <sup>1.5</sup> , x <sup>2.5</sup> or User defined (21 point curve)
Accuracy	±4mV or ±8μA
Digital filtering	Damping factor from 1 to 99
Transducer supply	24Vdc ±10% (to 160mA) output
CMRR	120dB to earth / 60db to signal 0V
'Internal' variables	
Values	<ul style="list-style-type: none"> <li>• Average of any selected inputs</li> <li>• Maximum of any selected inputs</li> <li>• Minimum of any selected inputs</li> <li>• Difference between any 2 inputs</li> <li>• <math>(IN_1 \times IN_2 \times IN_3 \times IN_4) / (IN_5 \times IN_6 \times IN_7 \times IN_8)</math></li> <li>• <math>(IN_1 - IN_2) \times IN_3</math></li> </ul>
Performance	
Temperature drift	Less than 0.005% full scale per °C
Response time (10 to 90%)	from 120 to 200ms (dF=1)
Input sample rate	200mS per Sample Inputs are sampled sequentially Disabled inputs are skipped

### AI8 Input Connections

Pin	Signal	
1	Input 1 +	Analogue Current/Voltage Inputs
2	Input 2 +	
3	Inputs 1 & 2 -	
4	Input 3 +	
5	Input 4 +	
6	Inputs 3 & 4 -	
7	Input 5 +	
8	Input 6 +	
9	Inputs 5 & 6 -	Field Supply
10	Input 7 +	
11	Input 8 +	
12	Inputs 7 & 8 -	
13	0Vdc (out)	
14	24Vdc (out)	

### Ordering Information

Type	Cat. No.
(Model [1][2][3][4]) See key below	
AI8 2012	7940018246
AI8 2042	7940011206
AI8 2112	7940018247
AI8 2142	7940015938
AI8 0042	7940018245

Note: For other ranges please specify AI8 [1][2][3][4] where:

- 1 = No. of analogue output channels (0 or 2)
- 2 = No. of digital communications channels (0 or 1)
- 3 = No. of relays fitted (1 or 4 only)
- 4 = Power supply (1 for 'High Voltage' Version (1 for 'High Voltage' Version 2 for 'Low Voltage' Version)

Example: AI8 0112 (AI8 with digital comms, 1 alarm output, and 'low voltage' power supply)

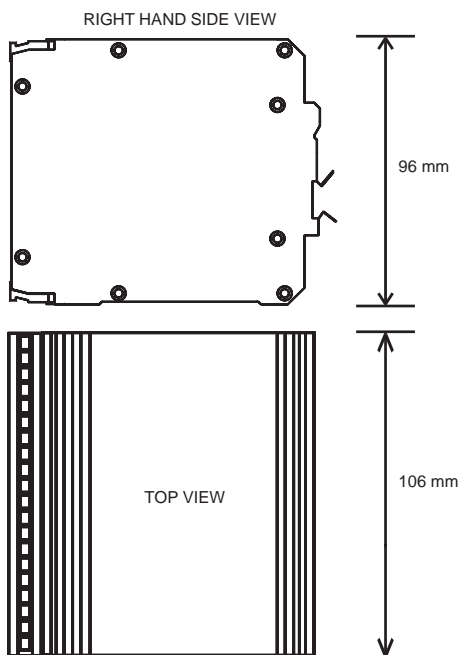

Effective depth :  
 120mm (Top Hat 35mm +/- 0.3, DIN 46277-3, EN 50022)  
 125mm (G - Rail 32mm +/- 0.3, DIN 46277-1, EN 50035)  
 To surface (including rail/mounting plate)

**RI4 4 channel Temperature (RTD) module/display**

- Four RTD temperature inputs
- Any combination of PT100 or Ni120 RTD's
- All channels individually linearised to temperature
- Automatic lead length compensation
- Inbuilt average, maximum, minimum and difference functions
- Display in °C or °F



RI4 - DIN rail mount module

Technical Data

Inputs			
Type	Temperature (RTD)		
RTD types	PT100 or Ni120		
Number of channels	4		
Standard range limits:			
RTD Type	Range	Resolution	Accuracy
PT100	-220°C to +850°C	0.382°C	0.5°C
	-220°C to +220°C	0.16°C	0.5°C
Ni120	-80°C to +320°C	0.203°C	0.5°C
Linearisation		All inputs linearised to temperature	
Digital filtering		Damping factor from 1 to 99	
CMRR		120dB to earth / 60db to signal 0V	
'Internal' variables			
Values	Select any combination of inputs for: <ul style="list-style-type: none"> <li>• Average measured temperature</li> <li>• Maximum measured temperature</li> <li>• Minimum measured temperature</li> <li>• Difference between any 2 temperatures</li> </ul>		
Performance			
Accuracy	See table under 'inputs'		
Temperature drift	Less than ±0.01% of span per °C		
Response time (10 to 90%)	from 120 to 200mS (dF=1)		
Input sample rate	200mS per Sample Inputs are sampled sequentially Disabled inputs are skipped		

**RI4 Input Connections**

Pin	Signal	
1	A	RTD Input channel one
2	B	
3	B <sub>sense</sub>	
4	A	RTD Input channel two
5	B	
6	B <sub>sense</sub>	
7	A	RTD Input channel three
8	B	
9	B <sub>sense</sub>	
10	A	RTD Input channel four
11	B	
12	B <sub>sense</sub>	
13	Not used	
14		

**Ordering Information**

Type	Cat. No.
(Model [1][2][3][4]) See key below	
RI4 0012	7940017071
RI4 0042	7940018248
RI4 2142	7940018250

Note: For other ranges please specify RI4 [1][2][3][4] where:

- 1 = No. of analogue output channels (0 or 2)
- 2 = No. of digital communications channels (0 or 1)
- 3 = No. of relays fitted (1 or 4 only)
- 4 = Power supply (1 for 'High Voltage' Version, 2 for 'Low Voltage' Version)

Example: RI4 0012 (RI4 with 1 alarm output, and 'low voltage' power supply)

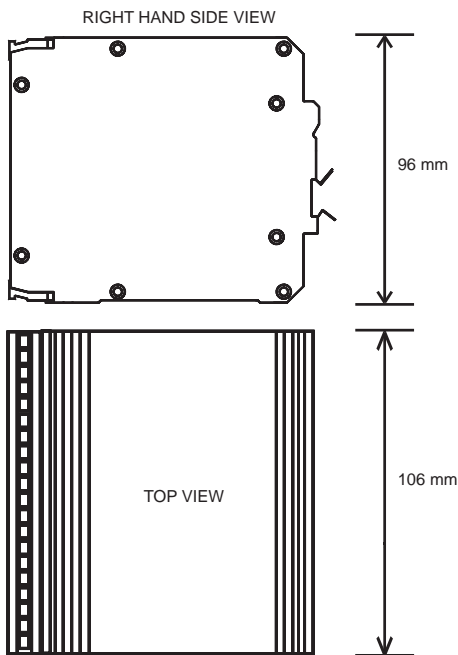

Effective depth :  
 120mm (Top Hat 35mm +/- 0.3, DIN 46277-3, EN 50022)  
 125mm (G - Rail 32mm +/- 0.3, DIN 46277-1, EN 50035)  
 To surface (including rail/mounting plate)