

Micromann Analogue to Frequency Converters

UPIR Low Frequency Outputs
UPIT High Frequency Outputs



Micromann universal analogue to frequency converters accept an analogue signal and convert it to a proportional output frequency.

- Accept any common current or voltage signal format
- 24Vdc supply for active input devices
- Frequency pulse output
- Programmable low-cut-off level (to prevent accumulated errors at low input levels)
- Inbuilt linearisation for square law signals
- Single alarm channel
- Display in Engineering units
- Complete isolation
- AC or DC powered
- Removable, screw-type, terminal blocks
- Compact metal housing



Australia

Weidmüller Pty Ltd.
43 Huntingwood Drive, Huntingwood
NSW 2148
Phone +61 (0) 2 9671 9999
Fax +61 (0) 2 9671 9900
Info@weidmuller.com.au
www.mannseries.com

United Kingdom



Weidmüller Ltd.
1 Abbey Wood Road, Kings Hill
West Malling, Kent ME19 4YT
Phone +44 1732-877032
Fax +44 1732-873873
Info@weidmuller.co.uk
www.weidmueller.com

Other countries

Weidmüller Interface GmbH & Co.
Postfach 3030
32720 Detmold
Phone +495231-14-0
Fax +495231-14-2083
info@weidmueller.com
www.weidmueller.com

Micromann Series Analogue to Frequency Converters

General Technical Data

Display	
Type	Full 4 digit, red 7mm LED
Scaling	Shows the output frequency in pulses per sec (Hz), pulses per minute or pulses per hour.
Display range	0 to 9999
Status indicators	Trip1 / Processor status
Inputs	
Input Type	Analogue current/voltage signals
Standard range limits	-55.00mA to +55.00mA or -55.00V to +55.00V (without recalibration)
Input impedance	22Ω (current inputs) 1MΩ (voltage inputs)
Resolution	1μA/1mV per bit for small ranges
Minimum recommended span	1mA or 1V
Linearisation	Linear or square root
Transducer supply	24Vdc (to 25mA) output
Power Supply	
Type	AC or DC powered
AC	110Vac (100-132Vac) at 47-63Hz or 240Vac (200-264Vac) at 47-63Hz
DC	12 to 50Vdc (other voltages on request)
Power Usage	AC 6VA or 6W at 24Vdc
Performance	
Linearity	Better than ±0.1% typical
Accuracy	Better than ±0.1% typical
Repeatability	±0.05% of span
Temperature drift	Less than 0.02% span per °C
Long term drift	0.1% per 10,000 hours
Reponse time	320ms for 10-90% output change
Input step response	Programmable (from 250mS to 32s)
Sampling rate	5 samples per second
Setup retention	100 years minimum
Insulation Co-ordination	
Ports	Input / Output / Case
Rated Insulation Voltage	300Veff
Overvoltage Category	III
Impulse Withstand	4kV (1.2 / 50)
Isolation	2 kV (between ports)
Environmental Conditions	
Operating temperature	0 to 60 °C
Storage temperature	-25 to +70 °C
Pollution Degree	2
Relative humidity	10-90% (non-condensing)
Housing	
Type	Registered Design, Dual DIN rail mount, Aluminium Enclosure
Dimensions	See diagram
Weight	0.5kg
Connection type	Plug in terminal blocks with screw connections
Options	
FC	Factory configuration - specify values for all settings
FPS	Custom transducer power supply
Approvals	
Micromann Series	 E256486  LV Directive EMC
Standard	
	CAN/CSA C22.2 No. 1010.1:92 UL61010-1: 2004 EN50178:1998 BS EN 61326:1998 + A2

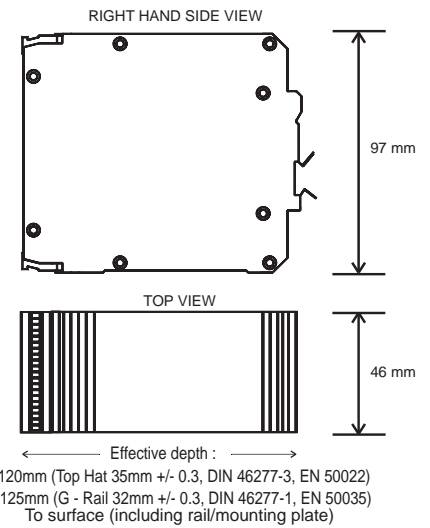

Connections

Terminal	Signal	
1	24Vdc (out)	Input (Current/Voltage) signals
2	Current +	
3	Common -	
4	Voltage +	
5	Not used	
6		
7	Link to change the set-up	Security Link
8		Power supply
9	Neutral (-)	
10	Live (+)	
11	See individual units	Alarm and Pulse outputs
12		
13		
14	Not Used	
15		
16		
Case	Earthing is via a stud on lower side of case	

Micromann Series Analogue to Frequency Converters (UPIR & UPIT)



UPIR Analogue to Frequency Converter

- SPDT relay contact frequency output
- For frequencies up to 25Hz
- Single SPDT alarm channel

UPIT Analogue to Frequency Converter

- Open collector transistor output
- For frequencies up to 1kHz
- Single open collector transistor alarm channel

Technical Data

Pulse output

Type	SPDT relay contact closures (frequency according to input level)
Max frequency	25Hz
Output resolution	
Pulse rate units	Per second, minute or hour
Isolation	Fully isolated

Alarm output

Type	SPDT relay contact
Coil energisation	Normally Energised (NE) or Normally De-energised (ND)
Alarm reset	Manual or automatic
Alarm time delay	From 0 to 4200 seconds
Deadband range	In 1 display unit increments
Setpoint range	Any value in the display range
Contact rating	3A @ 240Vac (resistive load) 3A @ 24Vdc/110Vac (resistive load) Note : A suppressor capacitor should be used (to increase contact life) when switching inductive loads.

Type	Isolated O/C transistor output (frequency according to input level)
Max frequency	999.9Hz
Output resolution	2 microseconds
Pulse rate units	Per second, minute or hour
Isolation	Pulse output shares a common negative return with the alarm output

Type	Isolated O/C transistor output
Coil energisation	normally energised ("on") or normally de-energised ("off")
Alarm reset	Manual or automatic
Alarm time delay	From 0 to 4200 seconds
Deadband range	In 1 display unit increments
Setpoint range	Any value in the display range
Contact rating	To 200mA "on" state current or 50Vdc "off" state voltage Note: back-emf diodes must be used for inductive loads.

Connections

Terminal	Signal	
11	Normally Closed	Alarm output
12	Common	
13	Normally Open	
14	Normally Closed	Frequency output
15	Common	
16	Normally Open	

Terminal	Signal
11	Alarm Output
12	Frequency Pulse output
13	0V

Ordering Information

Specify as

Where	Type (Model Supply)	Cat. No.
	UPIR 12-50Vdc	7940010908

Note: For other ranges please specify as UPIR 1 where:
1 = Power Supply Voltage

Specify as

Where	Type (Model Supply)	Cat. No.
	UPIT 12-50Vdc	7940015988

Note: For other ranges please specify as UPIT 1 where:
1 = Power Supply Voltage