

T-SERIES INDUSTRIAL POWER SUPPLIES INSTALLATION INSTRUCTIONS

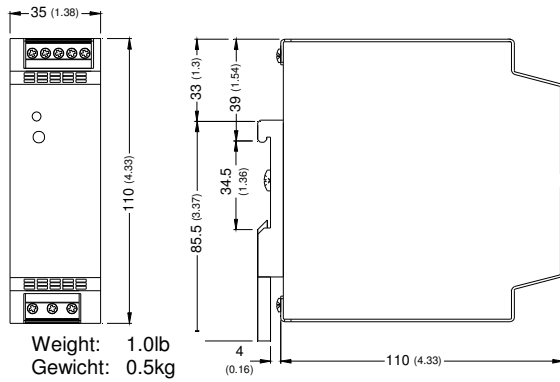

T-Series Dimension drawings:

CP T SNT 70W 12V 6A, CP T SNT 90W 24V 3.8A



CP T SNT 140W and CP T SNT 180W variants

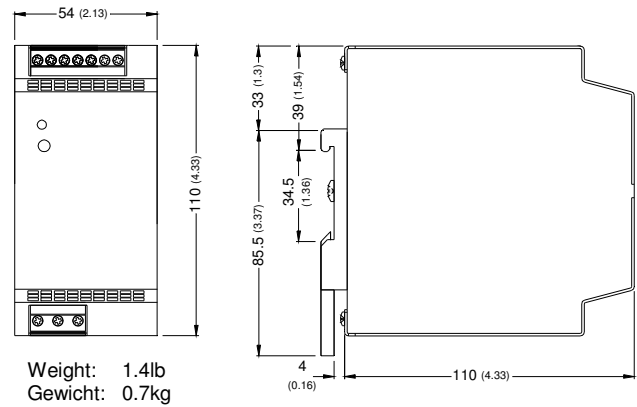

CP T SNT 360W (24v 15A, 48V 7.5A)

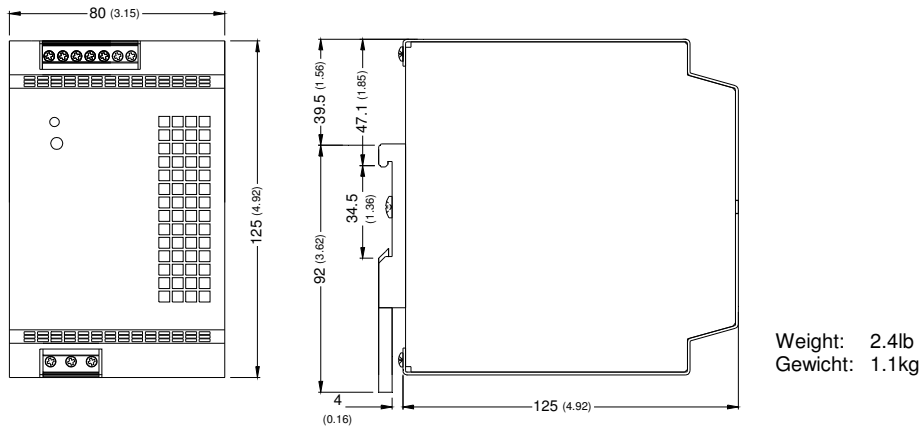

CP T SNT 600W (24V 25A, 48V 12.5A)

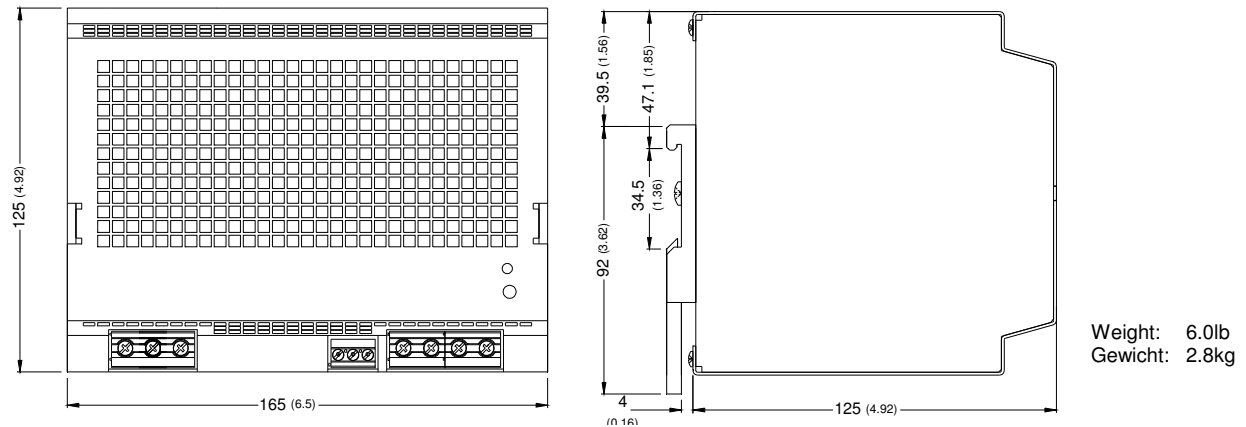

Note

This instruction cannot claim all details of possible equipment variations, nor in particular can they provide for every possible example of installation, operation or maintenance. Further information is available from your local distributor office or from the T-Series data sheet. Subject to change without prior notice.

In order to guarantee safe operation of these power supplies and to be able to make use of all the functions, please read these instructions thoroughly!

Warning

The power supplies are constructed in accordance with the safety requirements of IEC/EN/UL 60950-1, CSA-C22.2 No. 60950-1-03, UL508, CSA-C22.2 No. 14-95, EN60204, EN50178, EN61558-2-4, CSA C22.2 No. 213 (Class I and II, Division 2) and ANSI/ISA 12.12.01. They fulfil the requirements for CE-compatibility and carry the CE-mark and are UL & cUL approved by CSA and UL.

The T Series built-in power supplies were designed especially for use in process automation and other industrial applications. Components with dangerously high voltage and high stored energy are located in the device. However, these are inaccessible. Failure to properly maintain the power supply can result in death, severe personal injury or substantial property damage. **The power supplies may only be installed and put into operation by qualified personnel.** The corresponding national regulations (e.g. UL, CSA, ANSI, VDE, DIN) must be observed. The successful and safe operation of this power supply is dependent on proper storage, handling, installation and operation.

The potentiometer to adjust the output voltage is only allowed to be actuated using an insulated screwdriver, because accidental contact may be made with parts inside the power supply carrying dangerous voltages.



Please observe following points before putting the device into operation:

- Read operating instructions thoroughly.
- That the mains connection has been carried out by a competent person and protection against electrical shock is guaranteed!
- That the device can be disconnected outside the power supply in accordance with the regulations as in IEC/EN/UL/CSA 60950 or other national regulations.
- That the protective earth is connected.
- That the input wiring is sufficiently protected and dimensioned!
- That the output wiring is dimensioned according to the maximum output current or separately protected!
- Sufficient cooling is guaranteed!
- The temperature of the housing can become very high, depending on the ambient temperature and load.

Caution:

Risk of electrical shock and electrical discharge. The power supply must not be opened until at least 5 minutes after complete disconnection of the mains.

Electrostatic sensitive device. **Qualified and trained personnel only may open the power supply.**

Attention: In case of non-observance or exceeding the mentioned limiting value of the data sheet, the function and electrical safety can be impaired and can destroy the power supply.

Before installation ensure that the main switch is switched off and prevented from being switched on again. In case of non-observance, touching of any live components or improper dealing with this power supply can result in death or fatal injury.



Danger: Never work on power supplies if power is applied!



1. Description and construction

The T Series power supplies are built-in units. The mounting position has to fulfil the requirements for fireproof case according to UL60950, IEC/EN 60950 or other appropriate national standard. The relevant UL regulations or equivalent national regulations must be observed during installation.

The T-SERIES power supplies are designed for mounting on a DIN rail TS35 (DIN EN 50022-35x15/7.5) and for operation from 115 or 230VAC, 50/60Hz (Universal input voltage range for CP T SNT 70W 12V 6A, CP T SNT 90W 24V 3.8A and auto range for CP T SNT 140W 12V 12A, CP T SNT 180W 24V 7.5A, CP T SNT 180W 48V 4A, CP T SNT 360W 24V 15A, CP T SNT 360W 48V 7.5A, CP T SNT 600W 24V 25A and CP T SNT 600W 48V 12.5A single-phase systems.

The output voltage of the T-SERIES power supplies is potential-free (floating), protected against short circuit and open circuit conditions (see Fig 1.1, Fig 1.2 and Fig 1.3).

2. Installation

A sufficiently strong DIN-rail has to be provided. The correct mounting position for optimal cooling performance must be observed. Above and below the power supply a minimum free space of 80mm [3.15in] is required and on each side of the power supply a minimum space of 50mm [1.97in] is required which allows air convection. The air temperature measured 10mm [0.39in] below the power supply must not exceed the specified values in the data sheet. Observe power derating above ambient temperatures of 40°C and at low line. (see Fig 4.1 and Fig 4.2)

2.1 Assembly

To fix unit on the DIN-rail, hook top part of clip on DIN-rail, push down- (see Fig 2.1) and inwards (see Fig 2.2) until you hear a clipping sound.

To remove the unit, pull the latch of the clip with the aid of an insulated flat head screwdriver (see Fig 2.3). When clip has cleared bottom DIN rail remove the screwdriver from recess. Lift the unit off DIN-rail. See Fig 2.4.

Wall mounting or chassis mounting can be achieved by use of optional mounting brackets **CP MB01** (1 bracket, see Fig. 6.1) for CP T SNT (70W 12V 6A, 90W 24V 3.8A, 140W 12V 12A, and 180W xx) or **CP MB02** (2 brackets, see Fig. 6.2 and Fig. 6.3) for CP T SNT (360W xx, 600W xx) . Remove the DIN-clips by removing the screw and place the mounting brackets in the same place as the DIN-clips.

2.2 Connecting cable

Only qualified personnel may carry out the installation. The devices are equipped with PCB plug connectors (CP T SNT 70W 12V 6A, CP T SNT 90W xx, CP T SNT 140W 12V 12A, CP T SNT 180W xx and CP T SNT 360W xx) or PCB terminals (CP T SNT 600W xx). This reliable and easy-to-assemble connection method enables a fast connection of devices and a visible isolation of the electrical connection if necessary.

2.2.1 Input (Fig. 5.1, Fig 5.2, Fig 5.3 and Fig. 5.4 → Connector J1):

The 100-240VAC connection is made by using the L, N and \perp connections and has to be carried out in accordance with the local regulations. Sufficiently dimensioned input wiring has to be ensured (see 2.2.1.1). A protective device (fuse, MCB, etc; see 2.2.1.2) and an easily accessible isolating device for disconnecting the power supply from mains must be provided. The protective earth conductor has to be connected.

If flexible wires are used the wires have to be terminated. (e.g. by using ferrules)

Note: This unit contains an automatic input voltage selection switch. Do not change the input voltage from 110/115Vac to 230/240Vac without disconnecting the input supply line first.

2.2.1.1 Connections and terminal assignment

Unit	Terminals	Function	Solid or stranded wires		Torque	Stripping length
			[mm ²]	[AWG]	[Nm]	[mm]
CP T SNT (90W 24V 3.8A, 180W 24V 7.5A, 180W 48V 4A)	L1 & N	Input Voltage (85 – 264VAC or 115/240VAC)	0.5 ... 2.5	24 ... 12	0.5 – 0.6	7.0
	\perp	Protective Earth Conductor	0.5 ... 2.5	24 ... 12	0.5 – 0.6	7.0
	+ & -	Output Voltage (24VDC)	0.5 ... 2.5	24 ... 12	0.5 – 0.6	7.0
	Signal	DC-OK, active output and relay outputs	0.2 ... 2.5	32 ... 12	0.5 – 0.6	7.0
CP T SNT (70W 12V 6A, 140W 12V 12A, 360W 24V 15A, 360W 48V 7.5A)	L1 & N	Input Voltage (85 – 264VAC or 115/240VAC)	0.5 ... 2.5	24 ... 12	0.5 – 0.6	7.0
	\perp	Protective Earth Conductor	0.5 ... 2.5	24 ... 12	0.5 – 0.6	7.0
	+ & -	Output Voltage (12VDC and 24VDC)	1.0 ... 2.5	18 ... 12	0.5 – 0.6	7.0
	Signal	DC-OK, active output and relay outputs	0.2 ... 2.5	32 ... 12	0.5 – 0.6	7.0
CP T SNT (600W 24V 25A, 600W 48V 12.5A)	L1 & N	Input Voltage (115 / 230VAC)	1.0 ... 4.0	18 ... 10	0.5 – 0.6	7.0
	\perp	Protective Earth Conductor	1.0 ... 4.0	18 ... 10	0.5 – 0.6	7.0
	+ & -	Output Voltage (24VDC)	2.0 ... 4.0	12 ... 10	0.5 – 0.6	8.0
	Signal	DC-OK, active output and relay outputs	0.2 ... 2.5	32 ... 12	0.5 – 0.6	7.0

2.2.1.2 Internal Fuse

Model	Ratings	Marking	CAUTION: For continued protection against risk of fire replace with same type and rating of fuse! This fuse should be changed only by authorised and trained personnel because it is soldered on the board If the internal fuse is triggered, there is most probably an internal malfunction which must be inspected in the factory. Due to that return this device to your local distributor.
CP T SNT 70W 12V 6A	4.0 AH/250V	F1 → 4.0 AH/250V	
CP T SNT 90W 24V 3.8A	4.0 AH/250V	F1 → 4.0 AH/250V	
CP T SNT 140W 12V 12A	4.0 AH/250V	F1 → 4.0 AH/250V	
CP T SNT 180W xx	4.0 AH/250V	F1 → 4.0 AH/250V	
CP T SNT 360W xx	6.3 AH/250V	F1 → 6.3 AH/250V	
CP T SNT 600W xx	12.0 AH/250V	F1 → 12.0 AH/250V	

2.2.1.3 Recommended external Fuses (MCB)

Model	Ratings	Characteristic	Model	Ratings	Characteristic
CP T SNT 70W 12V 6A	6 - 16A / 250V	B	CP T SNT 180W xx	6 - 16A / 250V	B
CP T SNT 90W 24V 3.8A	6 - 16A / 250V	B	CP T SNT 360W xx	10 - 16A / 250V	B
CP T SNT 140W 12V 12A	6 - 16A / 250V	B	CP T SNT 600W xx	16 - 25A / 250V	B

2.2.2 Output (Fig. 5.1, Fig 5.2, Fig 5.3 and Fig. 5.4 → Connector J2):

The 12VDC, 24VDC or 48VDC connection is made using the "+" and "-" connections. All output terminals should be connected to the load. Make sure that all output lines are dimensioned according to the maximum output current (see 2.2.1.1) or are separately protected! The wires on the secondary side should have large cross sections in order to keep the voltage drops on these lines as low as possible.

To achieve a reliable and shockproof connection strip the connecting ends according 2.2.1.1. If flexible wires are used the wires have to be terminated. (e.g. by using ferrules)

At the time of delivery, the output voltage is either 12VDC, 24VDC or 48VDC. The output voltage can be set (using an insulated screwdriver) from 12 to 14VDC, 24 to 28VDC or 48 to 56VDC on the potentiometer (see Fig. 5.1, Fig. 5.2, Fig. 5.3 and Fig. 5.4).

The device is electronically protected against overload and short circuit. In the event of malfunction, the output voltage is limited to 20VDC for 12VDC units, 35VDC for 24VDC units or 60VDC for 48VDC units.

2.2.3 Signalling (Fig. 5.1, Fig 5.2, Fig 5.3 and Fig. 5.4 → Connector J2):

The two DC-OK outputs are for enabling monitoring of the functions of the power supply. A floating signal contact (see Fig. 5.1, Fig 5.2, Fig 5.3 and Fig. 5.4 → Connector J2, pin 6 & pin 7) and an active DC-OK signal (see Fig. 5.1, Fig 5.2, Fig 5.3 and Fig. 5.4 → Connector J2, pin 5) are available. The DC-OK LED also enables a visual evaluation of the function of the power supply directly on site.

2.2.3.1 Floating contacts (Fig. 5.1, Fig 5.2, Fig 5.3 and Fig. 5.4):

The floating signal contacts opens and signals a drop in the output voltage below: 12VDC units → between 9 and 11VDC; 24VDC units → between 18 and 22VDC; 48VDC units → between 36 and 44VDC. Relay contacts are available at CP T SNT 70W 12V 6A and CP T SNT 90W 24V 3.8A: Connector J2, pin 4 and pin 5 / CP T SNT 140W 12V 12A, CP T SNT 180W xx and CP T SNT 360W xx: Connector J2, pin 6 and pin 7 / CP T SNT 600W xx: Connector J5, pin 1 and pin 2). Signals and ohmic loads up to 30VDC and currents of up to 1A can be connected on the 12VDC and 24 VDC units or 48VDC and current up to 0.5A for 48VDC units. For heavily inductive loads such as relay, a suitable protection circuit (e.g. damping diode) is necessary.

2.2.3.2 Active signal output (Fig. 5.1, Fig 5.2, Fig 5.3 and Fig. 5.4):

11VDC \pm 1VDC (12VDC units), 22VDC \pm 2VDC (24VDC units) or 44VDC \pm 4VDC (48VDC units) is applied between the "DC-OK" (CP T SNT 70W 12V 6A and CP T SNT 90W 24V 3.8A: Connector J2, pin 3 / CP T SNT 140W 12V 12A, CP T SNT 180W xx and CP T SNT 360W xx: Connector J2, pin 5 / CP T SNT 600W xx: Connector J5, pin 3) and "-" (Connector J2, pin 1) and can carry up to 40mA max. (12VDC units) or 10mA max (CP T SNT 90W 24V 3.8A(N) or 20mA max. (other 24VDC units) or 15mA max (48VDC units). This signal output is referenced to – Vout (GND) and signals when the output voltage drops below: 12VDC units \rightarrow between 9 and 11VDC; 24VDC units \rightarrow between 18 and 22VDC; 48VDC units \rightarrow between 36 and 44VDC by switching from high to low.

The DC-OK signal is decoupled from the power output. It is thus not possible for parallel-switched devices to provide external supply. The DC-OK signal can be directly connected to a logic input for evaluation.

2.2.3.3 Signal loop:

The two above-mentioned signals can be easily combined.

Example: Monitoring of two devices.

Use the active signal output of device 1 and loop in the floating signal output of device 2. In the event of malfunctioning a common alarm is available. Up to 5 units can be looped in. This signal combination saves wiring costs and logic inputs.

2.2.3.4 DC-OK LED:

The DC-OK LED is a two colour LED which indicates the status of the output and enables visual evaluation of the function locally in the control cabinet. DC-OK LED green – normal operation. DC-OK LED red – output failure if input mains is still present.

3. Function

3.1 Output characteristic curve:

In the case that the ambient temperatures is not higher than +40 °C, the device can continuously supply Iout max (see datasheet). In the event of a higher load, the operating point follows the U/I characteristic curve by use of overcurrent protection. The output current is limited at Iout max. by use of a constant current characteristic with automatic restart if the short circuit or over load condition has been removed.

The U/I characteristic curve ensures that heavily capacitive loads can be fed without problems.

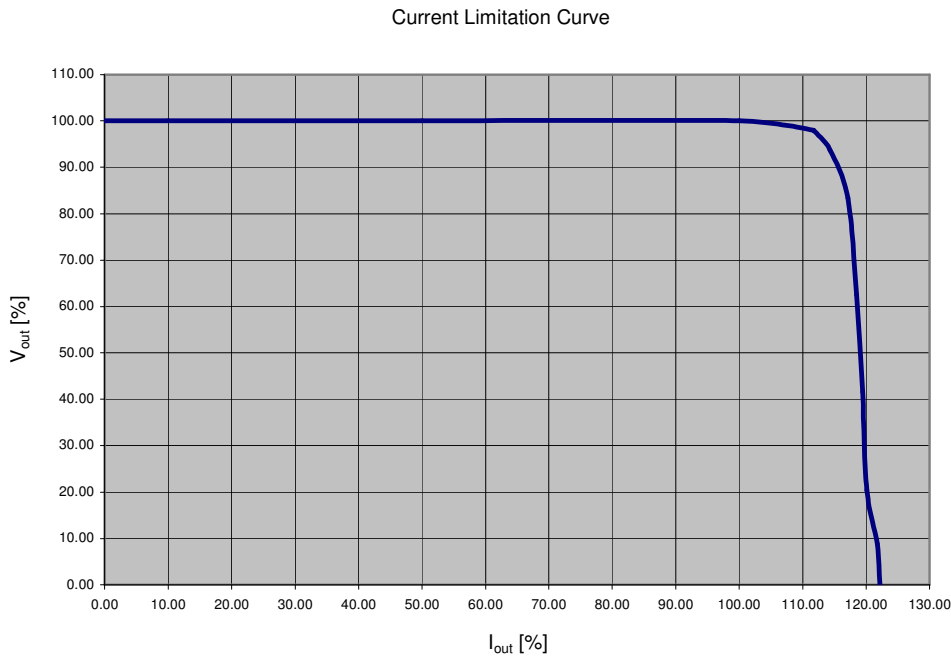

3.2 Thermal behavior:

The device should not be operated at higher loads than indicated on the derating graphs → Fig. 4.1 and Fig. 4.2). The device does switch off at thermal overload. After sufficient cooling the device will switch on again.

3.3 Parallel operation:

Maximum 5 devices of the same type can be connected in parallel to enable increased output power. For n parallel connected devices the output current can be increased to $n \times I_{max}$. Parallel connection to increase efficiency is used for the expansion of existing systems. It is advisable to use parallel connection if the power supply does not cover the current requirement of the most powerful consumer. Otherwise the consumers should be spread among individual devices independent of one another.

To provide a proper and reliable start-up the jumper at connector J4 has to be set (see Fig. 5.1, Fig. 5.2, Fig. 5.3 & Fig. 5.4). If the jumper is set between pin 1 and pin 2 of connector J4 the unit is in normal mode. If the jumper is set between pin 2 and pin 3 on connector J4 the unit can be paralleled. At delivery this jumper is set for normal operation (between pin 1 and pin 2 of connector J4).

If the output voltage is adjusted, a uniform distribution of power is guaranteed by setting all parallel operated power supplies to exactly the same output voltage. To ensure symmetrical distribution of power, we recommend designing all cable from the power supply as busbar of the same length and with the same conductor cross section. The system makes it advisable to install a protective circuit at the output of each device when more than two power supplies are connected in parallel (e.g. decoupling diode or DC fuse). This prevents high reverse feed currents in the event of a secondary device fault.

3.3.1 Redundancy operation:

Possible by use of our redundancy module CP T RM 10 or CP T RM 20. With this module and two power supplies of the T-Series (CP T SNT 70W 12V 6A, CP T SNT 90W 24V 3.8A, CP T SNT 140W 12V 12A, CP T SNT 180W 24V 7.5A and CP T SNT 360W 24V 15A in combination with CP T RM 10 or CP T SNT 600W 24V 25A in combination with CP T RM 20) a highly reliable, true redundant power system can be configured without any additional components. This module enforces the equivalent sharing of the output current by each power supply. The system is fully redundant and provides the output power even if one power supply has completely failed e.g. by short circuit on the output. In the event of either, one power supply failing or being disconnected, the second unit will automatically supply the full current to the load. The redundancy of the system is monitored and if lost, indicated by an alarm output. The inputs are hot swappable and can be loaded up to 15A each (CP T RM 10) or up to 25A each (CP T RM 20).

3.6 Remote ON/OFF:

The standard unit provides a remote on/off function by use of pin 2 at connector J3 (see Fig. 3.1, Fig. 5.1, Fig. 5.2, Fig. 5.3 & Fig. 5.4). To switch off the power supply a connection between Connector J3 pin 2 (-S) and Connector J2, pin 1 (-Vout) by use of a 1kΩ resistor has to be made. At open connection between J3 pin 2 and J2 pin 1 the device is providing the adjusted output voltage.

4. Additional information for the North American Market for UL508

The T-series power supplies are built-in units and must be installed in a cabinet with minimum dimensions of: 400mm (Width) x 500mm (Height) x 200mm (Depth)

4.1 Operating Temperature Ranges and load derating:

Model	Operating Temperature Range
CP T SNT 70W 12V 6A	-25 – 40°C → 100% (40 – 60°C → Load derating by 0.5 ^{W/°C}) (60 – 70°C → Load derating by 2.0 ^{W/°C})
CP T SNT 90W 24V 3.8A	-25 – 40°C → 100% (40 – 60°C → Load derating by 1.5 ^{W/°C}) (60 – 70°C → Load derating by 2.0 ^{W/°C})
CP T SNT 140W 12V 12A	-25 – 40°C → 100% (40 – 60°C → Load derating by 3.0 ^{W/°C}) (60 – 70°C → Load derating by 4.0 ^{W/°C})
CP T SNT 180W xx	-25 – 40°C → 100% (40 – 60°C → Load derating by 3.0 ^{W/°C}) (60 – 70°C → Load derating by 4.0 ^{W/°C})
CP T SNT 360W xx	-25 – 40°C → 100% (40 – 60°C → Load derating by 6.0 ^{W/°C}) (60 – 70°C → Load derating by 8.0 ^{W/°C})
CP T SNT 600W xx	-25 – 40°C → 100% (40 – 60°C → Load derating by 6.0 ^{W/°C}) (60 – 70°C → Load derating by 16.0 ^{W/°C})

6. Technical Specifications

6.1 Input Specifications

Model	* Input voltage range	max. Output-power	** Output voltage Factory Set $\pm 1\%$	*** Output current $I_{out\ max}$	Input current at full load typ.		Inrush current max. at +25°C (<2ms)		Efficiency typ. at 230VAC
					115 VAC	230 VAC	115 VAC	230 VAC	
CP T SNT 70W 12V 6A & CP T SNT 90W 24V 3.8A	100-240VAC 85-264VAC (47-63 Hz)	78 Watt 90 Watt	12 VDC 24 VDC	6.5 A 3.75 A	2.0 A 2.1 A	1.0 A 1.0 A	12.0 A	20.0 A	82.0 % 85.0 %
CP T SNT 140W 12V 12A & CP T SNT 180W 24V 7.5A, 48V 4A	100-120VAC/ 220-230VAC	156 Watt 180 Watt 192 Watt	12 VDC 24 VDC 48 VDC	13.0 A 7.5 A 4.0 A	2.5 A 2.8 A 2.8 A	1.4 A 1.5 A 1.5 A	13.0 A	25.0 A	85.0 % 88.0 % 90.0 %
CP T SNT 360W (24V 15A, 48V 7.5A)	85-132 VAC/ 187-264 VAC	360 Watt 360 Watt	24 VDC 48 VDC	15.0 A 7.5 A	5.0 A 5.0 A	2.5 A 2.5 A	16.0 A	25.0 A	87.0 % 89.0 %
CP T SNT 600W (24V 25A, 48V 12.5A)	(47-63 Hz) Auto range	600 Watt 600 Watt	24 VDC 48 VDC	25.0 A 12.5 A	10.0 A 10.0 A	5.0 A 5.0 A	25.0 A	30.0 A	89.0 % 91.0 %

* Observe output current derating at operation below an input voltage of 110VAC (see Fig. 4.2).

** Output voltage adjustable 12 - 14VDC, 24 - 28VDC and 48 - 56VDC

*** Maximum current at nominal output voltage ($V_{out\ nom}$) and operating temperature up to +40°C max.

6.2 Output Specifications

Regulation - Input Variation (Line Regulation) - Load Variation (Load Regulation)	$V_{in\ min} - V_{in\ max}$ 10% - 100% of $I_{out\ max}$	0.5% max 0.5% max 2.0% in parallel operation
Output Voltage adjustable Range with Potentiometer	12 V Model 24 V Model 48 V Model	12 - 14 VDC 24 - 28 VDC 48 - 56VDC
Ripple and Noise (20MHz Bandwidth)	at $V_{in\ nom}$ und $I_{out\ max}$	200mV pk-pk max
Overload protection	Thermal protection	Automatic restart
Electronic Short Circuit Protection	Continuous	Constant current. Automatic restart
Parallel Operation	all Models; User selectable standard mode and parallel mode by jumper on PCB	up to 5 Power Supplies possible (Jumper position see Fig. 5.1, 5.2, 5.3 & 5.4)
Over Voltage Protection (OVP)	Trigger point at	20VDC → 12VDC units 35VDC → 24VDC units 60VDC → 48VDC units
Hold-up Time	at full load and $V_{in} = 115VAC$ at full load and $V_{in} = 230VAC$	10ms min. 20ms min
Reverse Voltage Protection (Power back immunity)		16VDC 35VDC 63VDC
Status Indicator (two colours)	Green LED Red LED	Normal operation Output failure – if AC input mains is present
Power Good Signal	Trigger threshold 12VDC units 24VDC units 48VDC units Active output signals CP T SNT 70W 12V 6A (referenced to $-V_{out}$) CP T SNT 140W 12V 12A CP T SNT 90W 24V 3.8A 24VDC units 48VDC units Relay output → DC-OK = Contact closed	9 – 11 VDC 18 – 22 VDC 36 - 44 VDC 11.0VDC $\pm 1.0VDC$ / 20mA max. 11.0VDC $\pm 1.0VDC$ / 40mA max. 22.0VDC $\pm 2.0VDC$ / 10mA max. 22.0VDC $\pm 2.0VDC$ / 20mA max. 44.0VDC $\pm 4.0VDC$ / 15mA max. 30VDC / 1.0A max. for 12 / 24VDC models 48VDC / 0.5A max. for 48VDC models
Max. Capacitive Load		Unlimited

6.3 General Specifications

Operating Temperature Range	See Fig. 4.1 and Fig. 4.2	-25 °C ... +70 °C (above +40 °C load derating) -13 °F ... +158 °F (above +104 °F load derating)
Cooling		Convection cooling; no internal fan
Storage Temperature Range		-25 °C ... +85 °C -13 °F ... +185 °F
Load Derating above +40 °C (104 °F)		see Fig. 4.1
Humidity (non condensing)		95% rel H max.
Pollution Degree		2
Temperature Coefficient		0.02%/K
Reliability, calculated MTBF in accordance to IEC 61709	CP T SNT 60W xx CP T SNT 140W 12V 12A CP T SNT 120W xx, 240W, xx 480W xx)	>1.8 Mio. hours >1.2 Mio. hours >0.9 Mio. hours
Switching Frequency	depending on Model	50 ... 140kHz typ.
Remote ON/OFF	see Fig. 5.1, 5.2, 5.3 & 5.4	2 pin connector (see Fig. 3.1) connect -S via a 1kΩ to -Vout → Device off
Safety class	in accordance to IEC 536	Class 1
Case protection	in accordance to IEC 529	IP20
Isolation		See Safety Standards
—		
Safety and Hazardous Location Approvals	IEC SI-1729_B3 UL file E236157 UL file E255651 CSA file 246286 CSA file 246286 CSA file 246286 CSA file 246286 CE Mark	CB-Scheme as per IEC 60950-1 cULus Listed to UL508, CSA C22.2 No. 14 cRUus to ANSI/UL60950, CSA60950 CSA to C22.2 No. 107.1 cCSAus to CSA60950, ANSI/UL60950 cCSAus C1D2 to C22.2 No. 213, UL1604 cCSAus C1Z2 to CSA60079-15, UL60079-15 & ANSI/ISA 12.012.01 EN 60950-1, EN 50178, EN 61558-2-4
Electromagnetic compatibility (EMC) Emissions	in accordance to the product family standard Power Supply Industrial Area Conducted EMI on terminals Radiated EMI Input Current harmonics Flicker	EN 61204-3 EN 55022 Class B, EN 55011 Class B, FCC Part 15-B EN 55022 Class B, EN 55011 Class B, FCC Part 15-B EN 61000-3-2 Class A CP T SNT 70W 12V 6A and CP T SNT 90W 24V 3.8A → up to full output power CP T SNT 140W 12V 12A and CP T SNT 180W 24V 7.5A → up to 120 watt only CP T SNT 360W 24V 15A → up to 240 watt only CP T SNT 600W 24V 25A → up to 480 watt only EN 61000-3-3
Electromagnetic compatibility (EMC) Immunity	in accordance to the product family standard Power Supply Industrial Area Electrostatic discharge (ESD) Electrostatic discharge (ESD) Radiated RF Fields [80 – 1000MHz] Electrical fast transients / Bursts Electrical fast transients / Bursts Surge (Mains Supply) Surge (Mains Supply) Surge (Signal Supply) Immunity to conducted radio frequency disturbances [0.15-80MHz] Power frequency field immunity Voltage Dips Voltage sag immunity	EN 61204-3 Standard Level Description Perf. criteria IEC / EN 61000-4-2 ±4kV Contact discharge B IEC / EN 61000-4-2 ±8kV Air discharge B IEC / EN 61000-4-3 10V/m B IEC / EN 61000-4-4 ±2kV Mains Supply B IEC / EN 61000-4-4 ±1kV Signal Supply B IEC / EN 61000-4-5 ±1kV between L & N B IEC / EN 61000-4-5 ±2kV between L & PE and N & PE B IEC / EN 61000-4-5 ±1kV between ax & PE B IEC / EN 61000-4-6 10V B IEC / EN 61000-4-8 30A/m B IEC / EN 61000-4-11 70% UN / 40%/100% UN B / C SEMI F47
Environment	Vibration Shock	IEC 60068-2-6 3 axis, sine sweep, 10 ... 55Hz, 1g, 1oct/min. IEC 60068-2-27 3 axis, 15g, half sine, 11ms
Enclosure Material		Aluminium (Chassis) / Zinc plated Steel (Cover)
Mounting	DIN-Rail mounting Wall mounting	For DIN-Rails as per EN 50022-35 x 15 / 7.5 (snap-on self-locking spring) With wall mounting bracket
Connection		Pluggable screw terminals (plugs included)



Block diagram CP T SNT 70W 12V 6A, CP T SNT 90W 24V 3.8A, CP T SNT 90W 24V 3.8AN &

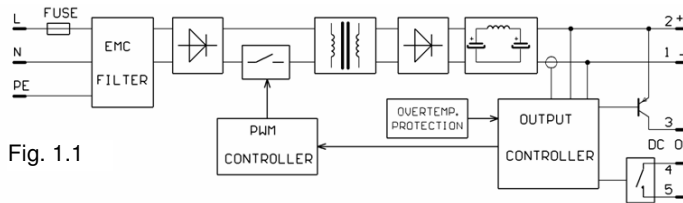

Fig. 1.1

Block diagram CP T SNT 140W 12V 12A, CP T SNT 180W 24V 7.5A, CP T SNT 180W 48V 4A, CP T SNT 360W 24V 15A & CP T SNT 360W 48V 7.5A

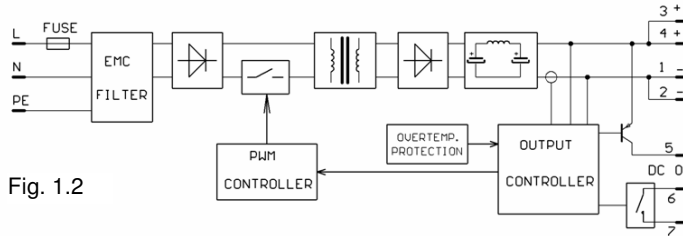

Fig. 1.2

Block diagram CP T SNT 600W 24V 25A & CP T SNT 600W 48V 12.5A

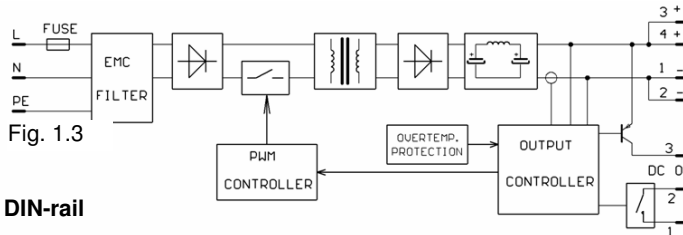

Fig. 1.3

To fix the power supply on DIN-rail

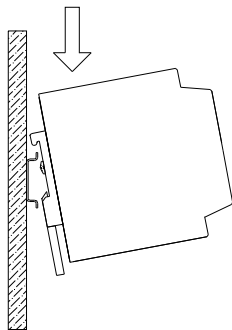

Fig. 2.1

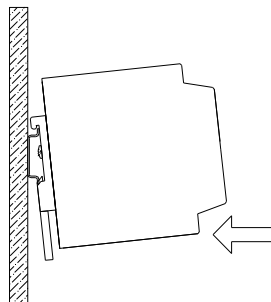

Fig. 2.2

To remove the power supply from DIN-rail

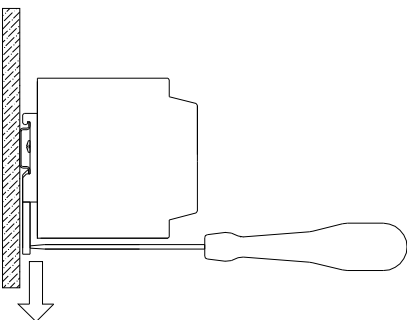

Fig. 2.3

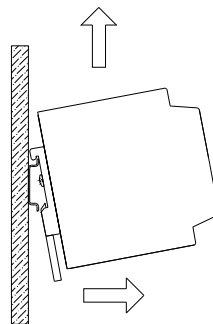

Fig. 2.4

Remote ON/OFF function

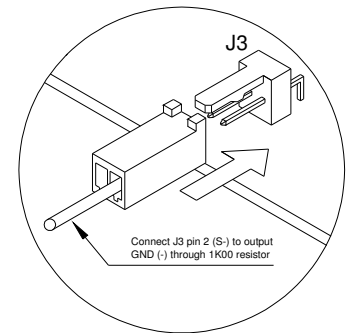

Fig. 3.1

Load Derating at operating temperatures above 40 °C

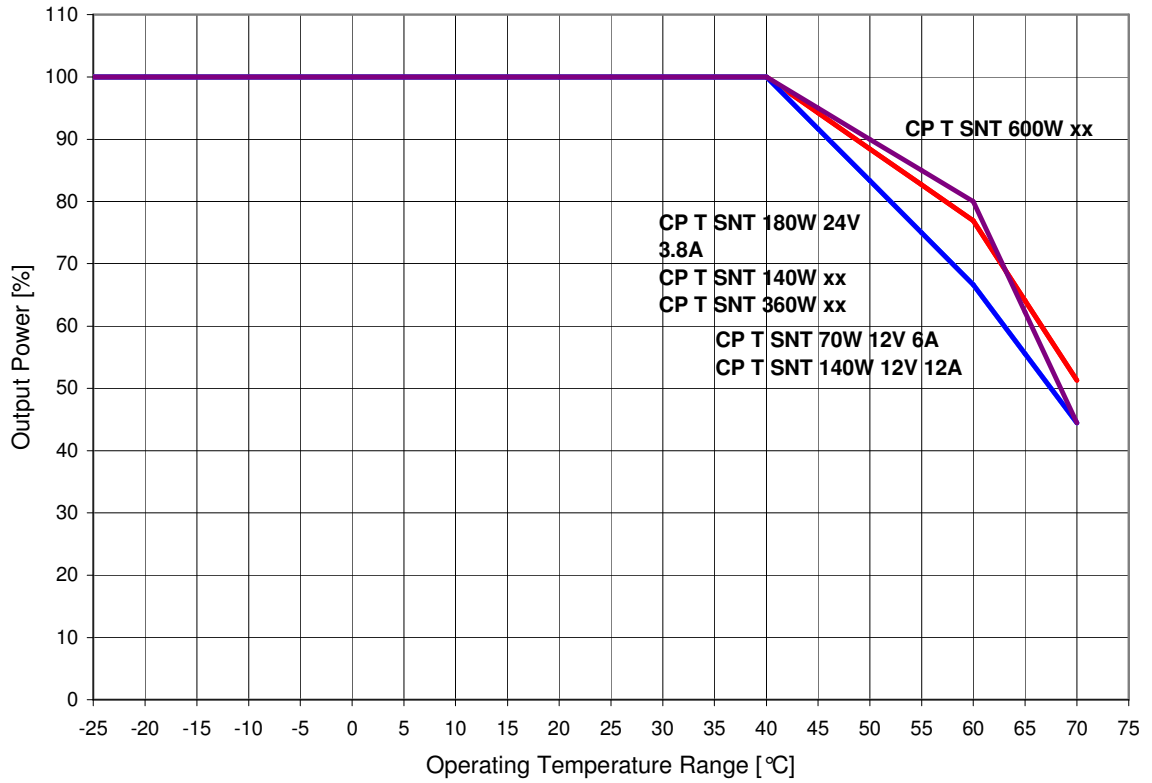

Fig.: 4.1

Load Derating at low input voltage

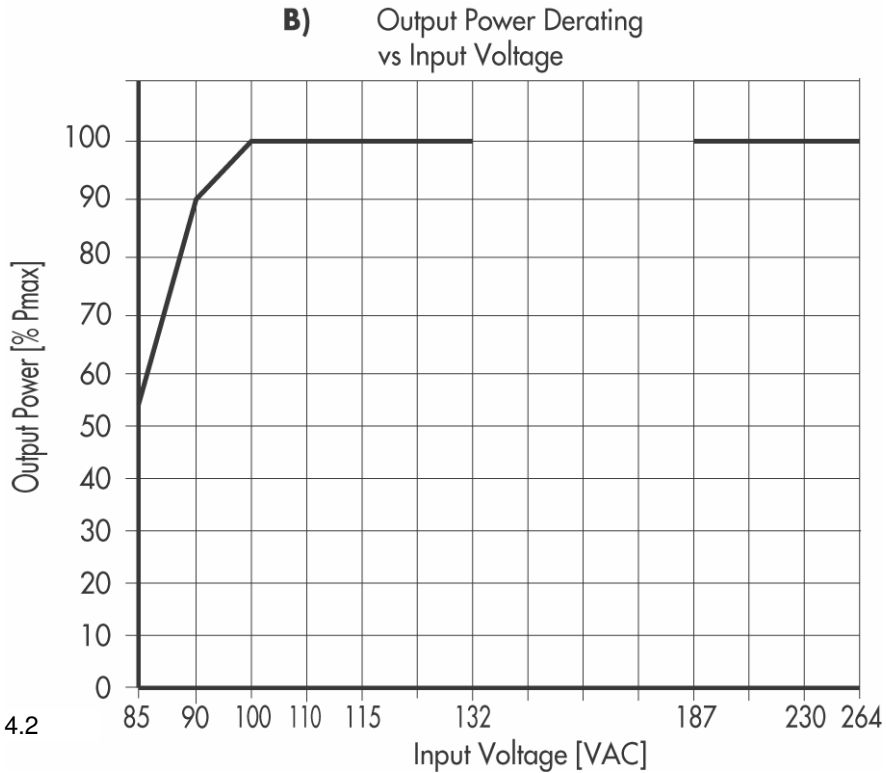

Fig.: 4.2

Connectors of CP T SNT 70W 12V 6A & CP T SNT 90W 24V 3.8A with output Voltage adjustment

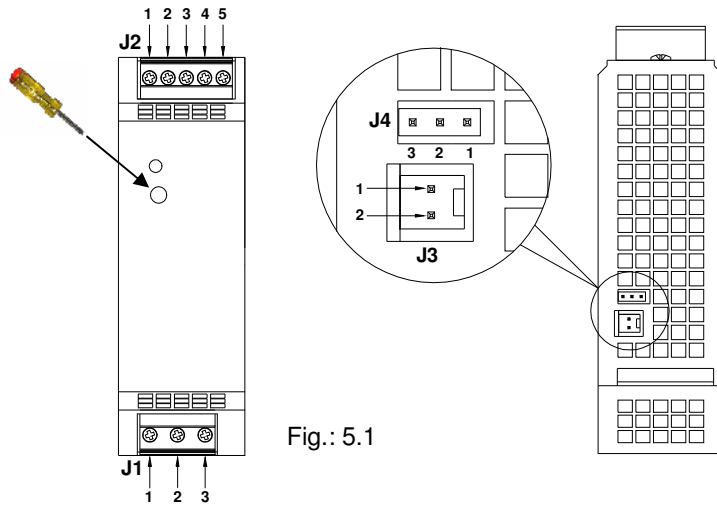

Fig.: 5.1

	J1	J2	J3	J4
Pin 1	Earth	GND (-)	S+	Normal mode
Pin 2	Neutral	Vout (+)	S-	Common
Pin 3	Live	DC-OK Signal	-	Parallel mode
Pin 4	-	DC-OK Relay contact 1	-	-
Pin 5	-	DC-OK Relay contact 2	-	-

Connectors of CP T SNT 140W 12V 12A, CP T SNT 180W 24V 7.5A & CP T SNT 180W 48V 4A with Output Voltage adjustment

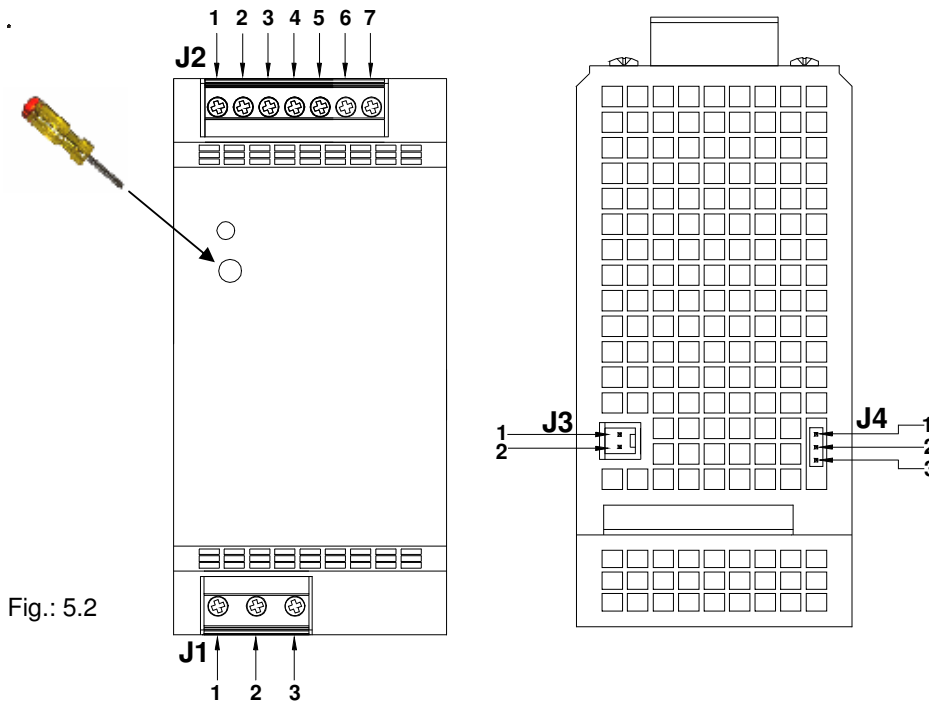

Fig.: 5.2

	J1	J2	J3	J4
Pin 1	Earth	GND (-)	S+	Normal mode
Pin 2	Neutral	GND (-)	S-	Common
Pin 3	Live	Vout (+)	-	Parallel mode
Pin 4	-	Vout (+)	-	-
Pin 5	-	DC-OK Signal	-	-
Pin 6	-	DC-OK Relay contact 1	-	-
Pin 7	-	DC-OK Relay contact 2	-	-

Connectors of CP T SNT 360W 24V 15A & CP T SNT 360W 48V 7.5A with Output Voltage adjustment

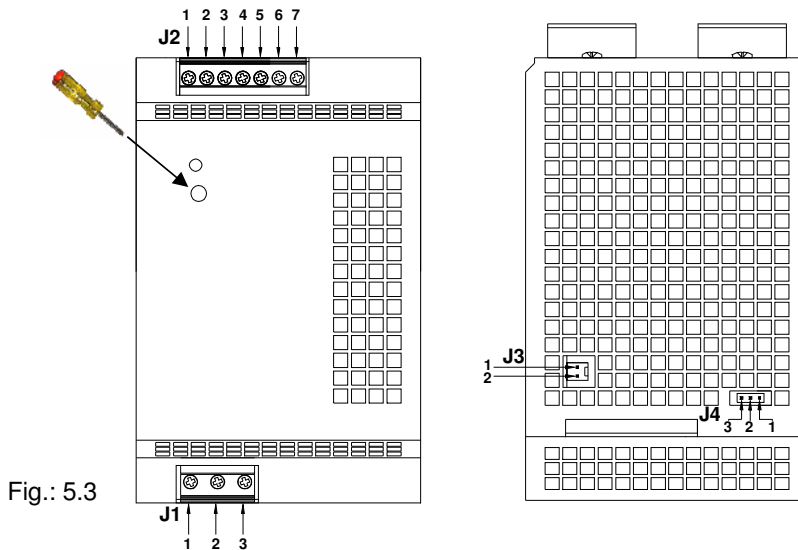

Fig.: 5.3

	J1	J2	J3	J4
Pin 1	Earth	GND (-)	S+	Normal mode
Pin 2	Neutral	GND (-)	S-	Common
Pin 3	Live	Vout (+)	-	Parallel mode
Pin 4	-	Vout (+)	-	-
Pin 5	-	DC-OK Signal	-	-
Pin 6	-	DC-OK Relay contact 1	-	-
Pin 7	-	DC-OK Relay contact 2	-	-

Connectors of CP T SNT 600W 24V 25A & CP T SNT 600W 48V 12.5A with Output Voltage adjustment

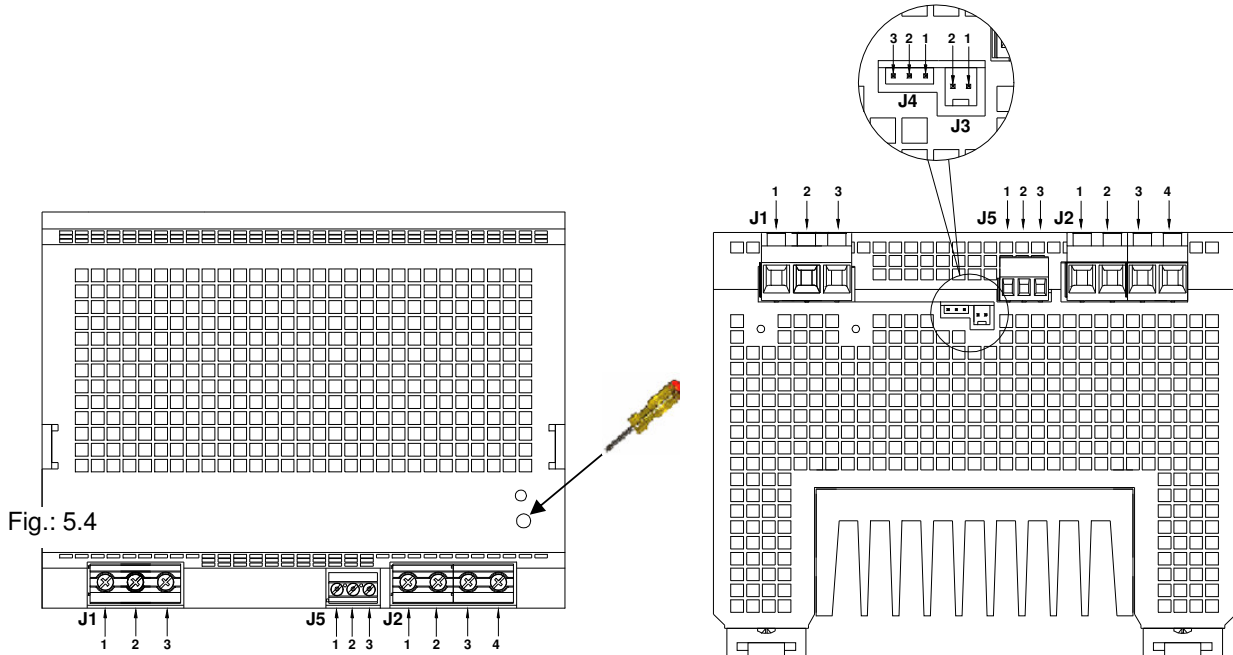
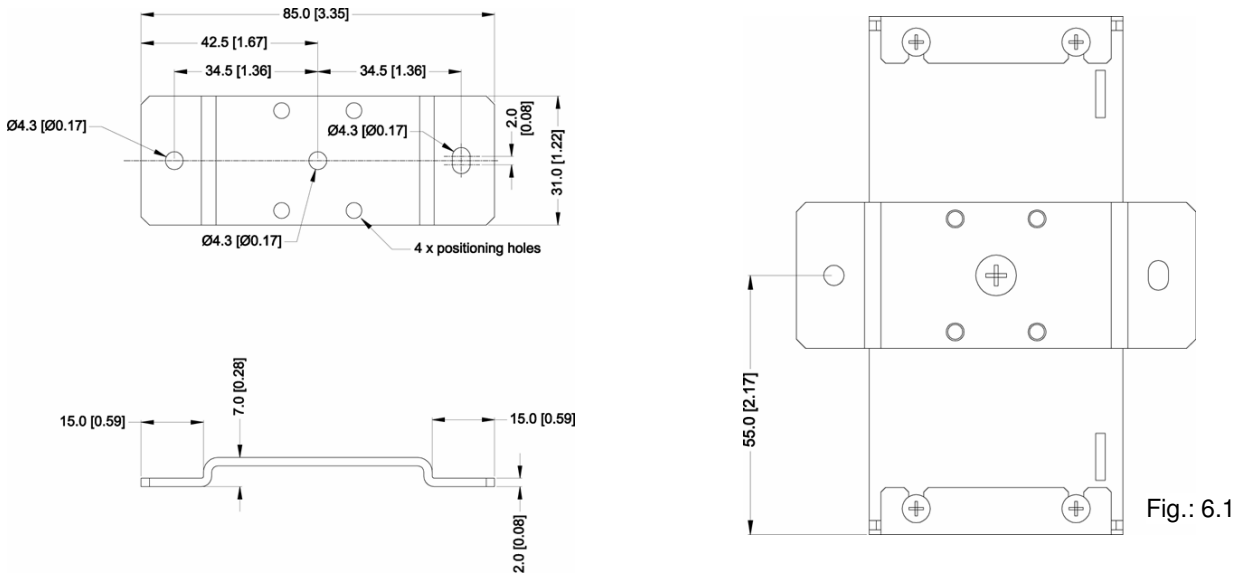

Fig.: 5.4

	J1	J2	J3	J4	J5
Pin 1	Earth	GND (-)	S+	Normal mode	DC-OK Relay contact 1
Pin 2	Neutral	GND (-)	S-	Common	DC-OK Relay contact 2
Pin 3	Live	Vout (+)	-	Parallel mode	DC-OK Signal
Pin 4	-	Vout (+)	-	-	-

Wall mounting brackets (CP MB01) for CP T SNT 70W 12V 6A, CP T SNT 90W 24V 3.8A, CP T SNT 140W 12V 12A and CP T SNT 180W xx



Wall mounting brackets (CP MB02) for CP T SNT 360W xx and CP T SNT 600W xx

