

Issue: Configuring a Turbo Ring V2 and additionally a Dual Ring

This Technical Note applies to the following Weidmüller Industrial Ethernet switches:

IE-SW-VL08MT-8TX
IE-SW-VL08MT-5TX-3SC
IE-SW-VL08MT-6TX-2ST
IE-SW-VL08MT-6TX-2SCS
IE-SW-PL08M-8TX
IE-SW-PL08M-6TX-2SC
IE-SW-PL08M-6TX-2ST
IE-SW-PL08M-6TX-2SCS
IE-SW-PL16M-16TX
IE-SW-PL16M-14TX-2SC
IE-SW-PL16M-14TX-2ST
IE-SW-PL10M-3GT-7TX
IE-SW-PL10M-1GT-2GS-7TX
IE-SW-PL18M-2GC-16TX
IE-SW-PL18M-2GC14TX2SC
IE-SW-PL18M-2GC14TX2ST
IE-SW-PL18M-2GC14TX2SCS
IE-SW-PL09M-5GC-4GT
IE-SW-PL06M-2TX-4PoE

What is Turbo Ring V2?

The Turbo Ring technology provides a ring redundancy with a healing time < 20 ms in case of a broken ring.

What is Dual Ring for Turbo Ring V2?

The “Dual-Ring” option provides another ring coupling configuration option, in which two adjacent Turbo Ring networks share one switch. This type of configuration is ideal for applications that have inherent cabling difficulties.

For example, in the diagram below Ring 1 is composed of Switch A, B and C. Ring 2 is composed of Switch C, D and E. Ring 1 and Ring 2 share Switch C. In other words, Switch C belongs to Ring 1 and Ring 2 at the same time.

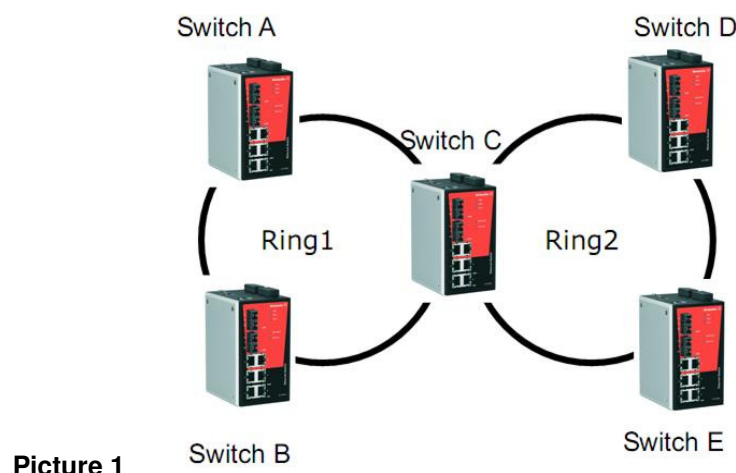

Picture 1

Enabling the Turbo Ring / Dual Ring network

1. Preparing 5 Turbo Ring devices one by one (i.e. Switch A, B, C, D and E as above diagram) to form 2 groups of Turbo Rings

Note: Enabling Turbo Ring V2 and Dual Ring will be done by using the web console

→ Do the followings steps 1.1 to 1.5 for each switch

- 1.1 Make sure that all DIP switches are set to OFF and then power on the switch.
- 1.2 Connect the host PC with the switch by Ethernet cable
- 1.3 Adjust the IP settings as necessary so that the switch is on the same network as your PC. You may also need to modify the host PC's IP configuration. Make sure you can ping the Weidmueller switch from your host PC.

Note: By default all Weidmüller managed switches have the IP address 192.168.1.110

- 1.4 Restore the Weidmueller switch to default settings via web console
- 1.5 Configure a unique IP address for the switch inside the Turbo Ring / Dual Ring network

Note: Assign the IP addresses in that way that each switch has its own IP address and all switches and connected PC's are in the same subnet

2. Enabling Turbo Ring V2 on Switches A (Master) and B (Slave) for Ring 1

→ see picture 2

- 2.1 Decide which two ports in switch A and B to use as the "1st Redundant Port" and "2nd Redundant Port" for Ring 1
- 2.2 The configuration has be done for Switch A and B through the web console as follows:
 - ▶ Communication Redundancy → Turbo Ring V2
 - ▶ Activate checkbox "**Enable Ring 1**" and select the "Redundant Ports 1st Port" and "Redundant Ports 2nd Port" that you have decided
 - ▶ Activate checkbox "**Set as Master**" only for **switch A** which will be the ring master
 - ▶ Activate the changes

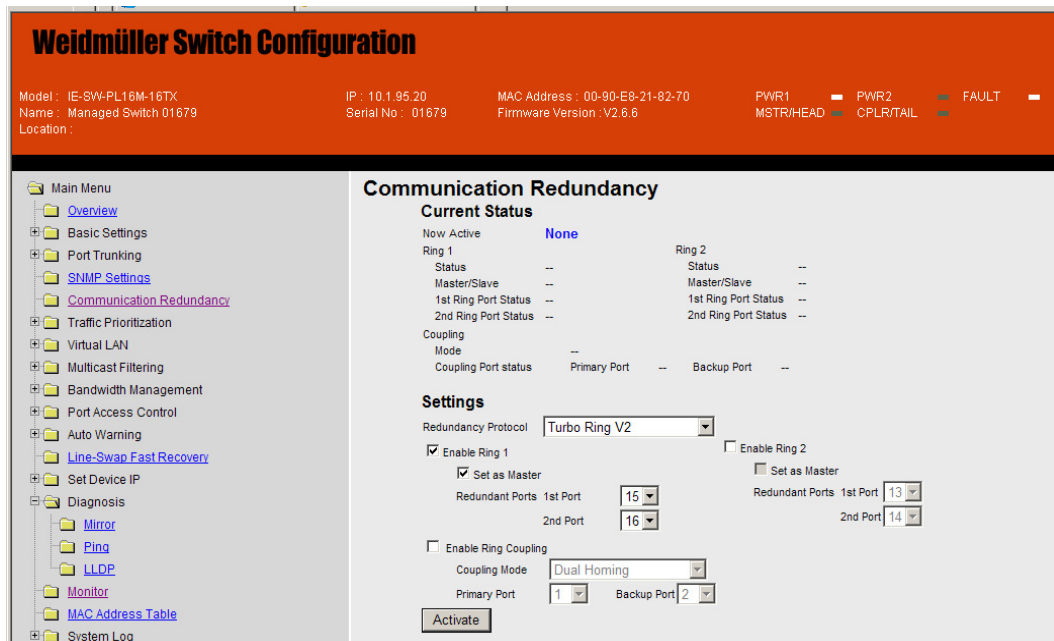

Picture 2

3. Enabling Turbo Ring V2 on Switches D (Master) and E (Slave) for Ring 2

→ see picture 3

3.1 Decide which two ports in switch D and E to use as the "1st Redundant Port" and "2nd Redundant Port" for Ring 1

3.2 The configuration has be done for Switch D and E through the web console as follows:

- ▶ Communication Redundancy → Turbo Ring V2
- ▶ Activate checkbox **“Enable Ring 2”** and select the “Redundant Ports 1st Port” and “Redundant Ports 2nd Port” that you have decided
- ▶ Activate checkbox **“Set as Master”** only for **switch D** which will be the ring master
- ▶ Activate the changes

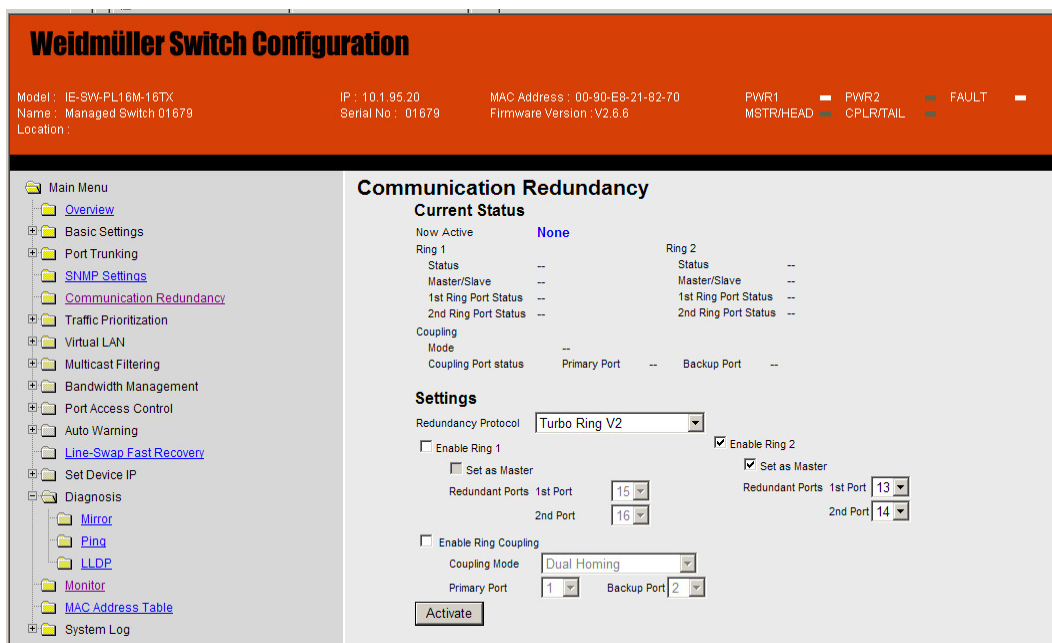

Picture 3

4. Now enable Turbo Ring V2 on Switch C for Ring 1 and 2 (the Result is a Dual Ring)

→ see picture 4

4.1 Decide which 2 ports in switch C to use

→ as the "1st Redundant Port" and "2nd Redundant Port" for Ring 1 and

→ as the "1st Redundant Port" and "2nd Redundant Port" for Ring 2

4.2 The configuration has be done for Switch C through the web console as follows:

▶ Communication Redundancy → Turbo Ring V2

▶ Activate checkbox **"Enabling Ring 1"** and select "Redundant Ports 1st Port" and "Redundant Ports 2nd Port" for Ring 1

▶ Then activate checkbox **"Enabling Ring 2"** and select "Redundant Ports 1st Port" and "Redundant Ports 2nd Port" for Ring 2.

▶ Activate the changes

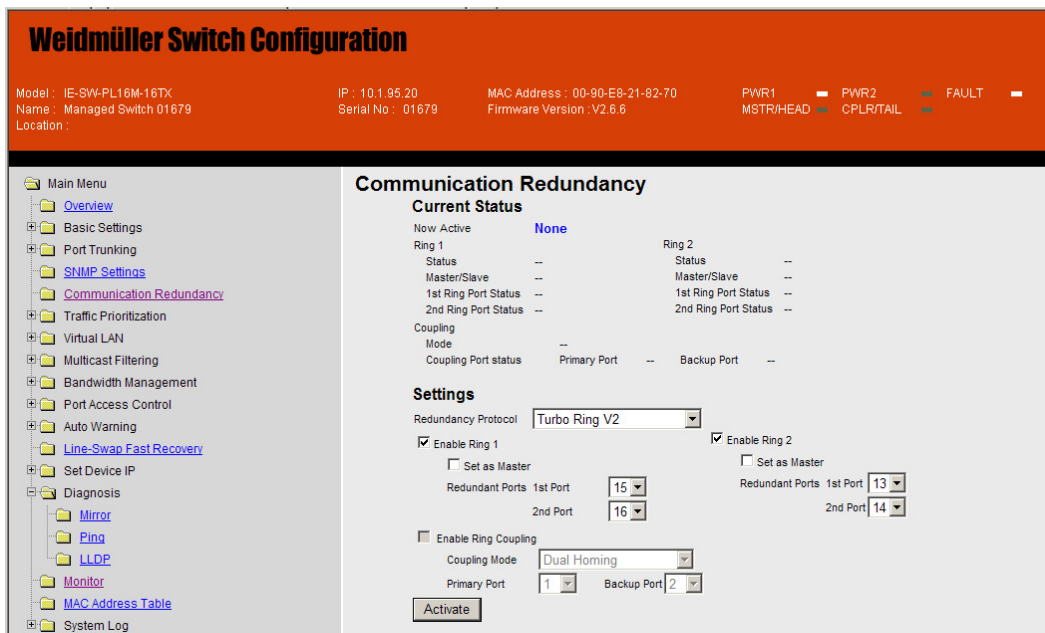

Picture 4

5. Connect all switches according to the configured Turbo Ring V2 ports

6. Monitor the port status of all switches in Ring 1 and Ring 2

Testing the Turbo Ring with Dual Ring function

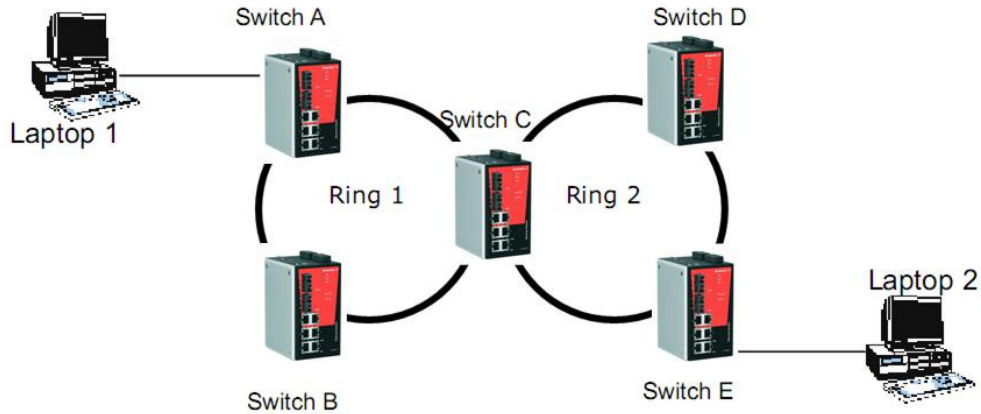

1. Configure Laptops 1 and 2 to be located in the same subnet.
2. Connect Laptop 1 to switch A and Laptop 2 to switch E.
3. Run a Ping x.x.x.x command from Laptop 1. (x.x.x.x is Laptop 2's IP address).
4. Unplug one of the Ring 1 path cables of switch C and confirm that the ping session recovers immediately.
5. Monitor the status of the 1st and 2nd redundant ports in Ring 1 and Ring 2.
6. Plug in the removed Ring 1 path of switch C and confirm that the ping session recovers immediately.
7. Monitor the status of the 1st and 2nd redundant ports in Ring 1 and Ring 2.